

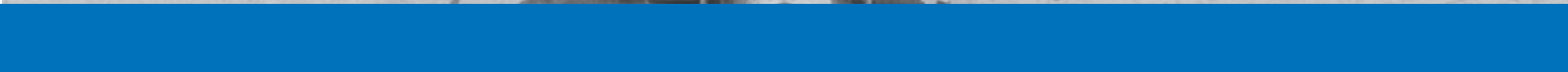

**SPM® Flow Control
Products Catalog**

SPM® Simplified Frac Iron on our
customer's frac site in west Texas



150 years of engineering intelligence

Weir has the products, services, expertise and engineering focus to design solutions precisely to your needs.

Weir Oil & Gas provides superior products and service solutions which make our upstream customers more efficient. More customers choose our pressure pumping solutions than any other. We provide well service and stimulation pumps, flow control products and replacement expendable parts.

In addition to the strongest technology, we know that engineered products are key to keeping you up and running. With Weir Edge™, you're fully covered. Our services platform is far from off-the-shelf. At the core of Weir Edge™ services are engineering experts who seek out the root cause of your equipment challenges so they can offer you custom solutions that work and technicians trained and audited to deliver quality. This is further controlled through our asset management program which provides tracking for each step of the repair process.





Commitment to Quality

Weir's Quality Management System (QMS) is qualified under ISO 9001 and 14001, as well as OHSAS 18001 requirements. Internal audits of Weir manufacturing and service centers are performed semi-annually to verify all policies are being followed and that lean focused continuous improvement drives value for the customer. External audits are performed at a minimum of every three years by a third party certifier. All products are manufactured in the United States.

Commitment to Safety

Weir is committed to managing its activities to safeguard its employees, clients, and the communities within which Weir operates in addition to the environment. Weir global QHSE standards have been disseminated throughout our operations. These standards, based upon a robust risk assessment approach and recognized QHSE management systems, provide a platform for continual improvement.

Commitment to Customers

Weir prioritizes its ability to provide a rapid response to service needs through its global network of Weir Edge™ service centers and engineering field assist teams. Service center teams are located in close proximity to all major shale plays and key production locations around the world to support customers with all repair and maintenance needs.

Contents

General Product Operation Notes	1
Service Types	1
Operating Temperature Range Classification.....	1
Operating Parameters	1
End Connections.....	1
Third Party Certifications	2
General Maintenance and Use Notes	2
General Usage	2
General Maintenance	2
Inspection–Repair–Testing	3
Recommended Storage.....	3
Product Flow Rates	3
General Safety Guide	5
Personal Responsibilities.....	5
On Site Considerations.....	5
Simplified Frac Iron	6
Instrumentation Skid	6
7" Plug Valve	7
7" Check Valve	7
Swivels	8
Swivel Configurations	9
Recommended Swivel Grease Procedure	13
Plug Valves	14
1" x 2" Plug Valve.....	15
2" Plug Valve (Standard).....	16
2" Light Weight Plug Valve	17
3" and 4" Plug Valves.....	18
Plug Valve Grease Procedure	20
Check Valves	21
Clapper Style Check Valves	22
EXL 3" Clapper Style Check Valves	22
2" and 4" Clapper Check Valves	23
Check Valves	24
Dart Style Check Valve	24
Relief Valves	26
Spring Style Relief Valve.....	27
Nitrogen Style Relief Valves	28
EXL Back Pressure Relief Valve	28
Full Bore Unloading Valve	29
Legacy Back Pressure N ₂ Valve.....	30
Relief Valve Stand Assemblies	30
SafeEdge™ Automated Relief Valve Control (ARC) System	31
EXL Pressure Relief Disc	32
Ball Injectors	33
Chokes	34
Adjustable and Positive Choke Valves.....	34
Integral Connections and Pipe	35
Integrals	35
Laterals	35
Tees	36
Wyes.....	37
Ells.....	37
Crosses	38
Pipe	39
NPS Pipe.....	39
Integral Pipe and Crossovers.....	41
Pup Joints	41
Integral Crossovers.....	42
Hose Loops	44
Hammer Unions	45
EXL Wing Nuts	46
Bull Plugs and Gauge Plugs	47
Safety Iron®	48
Assembly Specifications	48
Manifold Trailers	49
Trailer Flow Rate	50
Assembly Specifications	50
8-Station Manifold Skid	51
Flow Line Safety Restraint (FSR) System	52
FSR Rental Program	53
Other Safety Products	54
Safety Hammer.....	54
Inspection Services	55
Asset Management Program (A.M.P.)	56
Asset Management	56
Reporting	56
Inspection Management	56
Weir Edge	57

Service Types

Standard Service



Warning

Certain acids and chemicals may not be compatible with standard elastomers used in SPM® flow control products. Contact engineering for guidelines regarding elastomer compatibility.

- Alternative seals available for harsh services (chemicals, acids, etc.)
- Not intended for exposure to H₂S.

H₂S (Sour Gas) Service

- These assemblies are manufactured from tempered alloy (HSLA) steel and are in accordance with NACE MRO175 regarding allowable hardness and alloy concentration. These products are suitable for use with H₂S.



Warning

Exposing standard service components to H₂S may result in rapid catastrophic failures, which may lead to **SERIOUS BODILY INJURY, DEATH, OR PROPERTY DAMAGE**. Due to this risk, it is strongly recommended to only use H₂S service components for applications involving any concentration of H₂S.

Operating Temperature Range Classification

Product Classification	Minimum Temp	Maximum Temp
Standard Temp	0°C / 32°F	110°C / 230°F
Low Temp (Buna)	-30°C / -22°F	110°C / 230°F
Low Temp (Viton)	-30°C / -22°F	176°C / 350°F

NOTE: Temperature ratings are suitable for both standard service and H₂S service components.

Operating Parameters

Maximum Recommended Flow Rate: 42 ft/sec

End Connections

SPM® flow control products are available in hammer union or patented SPM® Safety Iron® end connections. Both end connection types are available in various sizes and pressure ratings. The most common include:

- 2" 1502 hammer union
- 3" 1502 hammer union or 15K SPM® Safety Iron® end connection
- 4" 1002 hammer union
- 4" 1502 hammer union or 15K SPM® Safety Iron® end connection

NOTE: Other parts or configurations may be available. Contact Weir for specific details. Product availability and specifications are subject to change at any time, with or without notice.

NOTE: H₂S service iron's operating pressure rating is derated from the union end connection nomenclature. The below table defines the working pressure rating for H₂S service product.

De-rated H₂S Operating Pressure

End Connection Type	Max Working Pressure (psi)
1002	7,500
1502	10,000
2202	15,000

Each integral union connection is clearly marked with an identification code (e.g. "1502"). This code should be referenced when mating unions. Improper mating can result in failures. All union connections used must match (according to size, pressure rating, etc.). These connections must also match the service of the designated string in which they are installed. (Std, H₂S, etc.)

All SPM® threaded components are right hand threaded unless specifically designated otherwise.

Third Party Certifications

CE and DNV certification for most flow control product families is offered. Additional third party certifications, such as ABS or BV, may be available upon request. Contact Weir for specific information.

General Maintenance and Use Notes

General Usage

- Personnel must take all appropriate steps to avoid being around pressure vessel products while pressure is present or being applied.
- Each treating iron component is clearly marked with a maximum pressure rating. Every string of iron should be pressure tested to its maximum planned working pressure prior to each use. Do not exceed the maximum rated pressure of any product in the flow line.
- Never tighten or hammer wing unions when flow line is under pressure.
- A complete visual inspection of flow control products must be made prior to each use. Any leaking seals, broken bolts, leaking hoses, or improperly tightened parts must be replaced or remedied prior to use.
- Treating iron connections should be properly cleaned and oiled before the downstream piping is attached. Any worn, damaged, or missing seals should be replaced.
- Weir recommends that users designate specific treating iron strings by application, and that the designated iron remain in that service application throughout the product's life. These service strings should be marked or color coded in such a way to be clearly identifiable.
- After each job flush components with clean water and grease applicable equipment with the proper Weir approved grease.
- Pressure seal (line pipe) threads are not recommended for pulsating service above 10,000 psi or where side loading or erosion are suspected. Non-pressure seal (round tubing) threads or integral connections are recommended under these conditions:
 - **All energized fluids and gases, such as CO₂ and N₂, are recommended to have a designated string of treating iron for that service.** This string must be clearly identified and must not be used for any other purpose. Pipe threaded components should never be used for energized service. Only integral union style components should be used.
 - Iron operating in applications using acids or other highly corrosive well fluids is recommended to have a designated string and should not be used for any other purpose.
 - **H₂S treating iron must also have a designated identification and always be used when H₂S is apparent or could be encountered.** Pipe threaded components should never be used for H₂S Service. Only integral union type components, designed for this service, should be used.
- Welding, brazing, or heating on high pressure components is prohibited.
- Flow rates above 42 feet per second are not recommended. Rates above 42 feet per second will cause accelerated wear. Certain abrasive media can also cause accelerated wear.

General Maintenance

- General maintenance will extend the life of flow control products.
 - Grease plug valves and swivel joints regularly. Reference specific greasing procedures and recommended intervals within each specific product's section of this document.
 - Replace worn or damaged seals to help prevent leaks and washouts of seal faces.
 - Clean all seal areas thoroughly.
- Flow lines should be flushed with clean water after each use. Care should be taken to avoid corrosive media from sitting stagnate in treating iron for extended periods of time.
- Use of proper tools is necessary when servicing SPM® flow control products. Service personnel must be knowledgeable and trained in the usage and handling of tools for all maintenance. Operating and maintenance manuals should be consulted before utilizing or performing maintenance on any product.

Inspection—Repair—Testing

- Flow control components must have regular intervals of maintenance and inspection to help provide safe, reliable performance. Further information regarding maintenance of specific product categories can be found in each product's corresponding operations and maintenance manual. Some users and particular operations may require more frequent maintenance and inspection intervals than recommended due to specific operating conditions. Weir Engineering can provide additional guidance to assist users in determining their inspection requirements.
- Only SPM® repair parts should be used for replacement in an SPM® product.
- Any unauthorized alteration of SPM® flow line equipment is prohibited.
- Use only repair methods as outlined by SPM® service literature. Use only the proper SPM® repair tools.
- Weir does not allow weld repair to be attempted on its flow control products. Replacing worn components is a more effective approach.

Recommended Storage

- Flow lines should be flushed with clean water prior to storage for extended periods of time.
- Plug valves and swivels should be greased prior to storage for extended periods of time.
- Plug valves should be stored in the open position.
- End connections and critical seal areas should be wiped dry prior to storage.
- Use a vapor phase corrosion inhibitor (VpCI) on the seal pocket, internal bores and thread connections.
- Thread protectors are recommended to be installed on end connections during general transport and storage.
- Flow control equipment should be stored in a controlled, clean, and dry environment when possible.
- Valves and swivels are recommended to be re-greased before being put into service if stored for an extended period of time.
- Valves and swivels are recommended to be pressure tested, including operational test, prior to being put in service if stored for an extended period of time.

Product Flow Rates

The following reference chart lists the maximum recommended flow rate by product family. The maximum flow rate is calculated based on internal diameter of the product from the factory and a maximum velocity of 42 feet per second. The published rates are applicable for both standard and H₂S service products.

Product Family	Size / Pressure	ID (inch)	Max Flow Rate (gpm)	Max Flow Rate (bpm)
Pipe (NPS—Hammer Union)	2 in / 1502	1.75 in	315	7.5
	3 in / 1502	2.56 in	674	16
	4 in / 1002	3.65 in	1,351	32.2
Pipe (Integral pup joints—Hammer Union)	2 in / 1502	1.75 in	315	7.5
	3 in / 1502	2.75 in	777	18.5
Pipe (Integral pup joints— SPM® Safety Iron®)	2 in / 15K	1.75 in	315	7.5
	3 in / 15K	2.75 in	777	18.5
	4 in / 15K	3 in	924	22
	5 in / 15K	4 in	1,646	39.2
Pipe (Integral crossovers—Hammer Union)	2 in / 1502	1.75 in	315	7.5
	3 in / 1502	2.75 in	777	18.5
	4 in / 1502	3.75 in	1,445	34.4
	4 in / 1502	3.75 in	1,445	34.4
Pipe (Integral crossovers—SPM® Safety Iron®)	2 in / 15K	1.75 in	315	7.5
	2 in / 15K	2 in	412	9.8
	3 in / 15K	2.5 in	643	15.3
	3 in / 15K	2.75 in	777	18.5
	4 in / 15K	4 in	1,646	39.2

Product Flow Rates (cont.)

Product Family	Size / Pressure	Max Flow Rate (gpm)	Max Flow Rate (bpm)
Integral Connections (Hammer Union)	2" 1502	315	7.5
	3" 1502	643	15.3
	4" 1002	1,446	34.4
	4" 1502	1,446	34.4
	2" 2002	176	4.2
	3" 2002	778	18.5
Integral Connections (SPM® Safety Iron®)	2" 15K	315	7.5
	3" 15K	643	15.3
	4" 15K	1,446	34.4
Plug Valve (Hammer Union)	1" x 2" 1502	90	2.1
	2" 1502	315	7.5
	3" 1502	778	18.5
	4" 1002	1,446	34.4
	4" 1502	1,446	34.4
	2" 2002	176	4.2
Plug Valve (SPM® Safety Iron®)	3" 2002	778	18.5
	2" 15K	315	7.5
	3" 15K	778	18.5
	4" 15K	1,446	34.4

Product Family	Size/Pressure	Max Flow Rate (gpm)	Max Flow Rate (bpm)
Clapper Check Valve (Hammer Union)	2" 1502	337	8
	3" 1502	674	16
	4" 1002	1,446	34.4
	4" 1502	1,446	34.4
	2" 2002	176	4.2
	3" 2002	778	18.5
Clapper Check Valve (SPM® Safety Iron®)	2" 15K	315	7.5
	3" 15K	778	18.5
	4" 15K	1,446	34.4
Dart Check Valve (Hammer Union)	2" 1502	315	7.5
	3" 1502	643	15.3
Swivel (Hammer Union)	2" 1502	315	7.5
	3" 1502	778	18.5
	4" 1002	1,446	34.4
	4" 1502	1,260	30
	2" 2002	176	4.2
	3" 2002	778	18.5
Swivel (SPM® Safety Iron®)	2" 15K	363	8.6
	3" 15K	778	18.5
	4" 15K	1,260	30

NOTE: Other parts or configurations may be available. Contact Weir for specific details. Product availability and specifications are subject to change at any time, with or without notice.

Personal Responsibilities

- Personnel must take all appropriate steps to avoid being around pressure vessel products while pressure is present or do not hammer on any SPM® product when pressure is present.
- When using SPM® flow control products appropriate personal protective equipment (PPE) is required, including, at a minimum, safety glasses, approved safety shoes, gloves and hard hat.
- Hammering and lifting must be done with caution.
- Personnel should only hammer on union lugs and not strike the union nut or valve body. Fractures can occur from repeated misuse. Excessive hammering can damage components.
- Legs should be used for proper lifting. Avoid using your back when lifting objects.
- Technicians should be trained in proper application and safe handling of SPM® flow control products prior to using.

On Site Considerations

- Proper transportation of SPM® products is important. Racks that secure valves and other components, and prevent accidental unloading, are critical. Never transport any SPM® product in a fashion that would allow it to become loose and cause an accident.
- End connections on SPM® products should be cleaned and oiled prior to each use. A visual inspection for damage should also be performed at this time. Union seals should be checked, and replaced when worn or damaged.
- Since SPM® products may be repainted in different colors for various applications, do not use factory color as the primary means of service identification. Operator should check end connection to confirm equipment ratings.
- Turning valves under pressure should be avoided due to the inherent risks of **SEVERE BODILY INJURY, DEATH, OR PROPERTY DAMAGE**. It is recommended that remote control actuators be used for this purpose, and that personnel remain outside of the zone of danger.
- SPM® product usage should be monitored by a qualified supervisor or foreman. Supervisory personnel must approve proper placement, position, and handling of all equipment in the pumping system.
- Do not position any part of your body in the path of exit flow of SPM® flow line equipment.
- Each string of iron should be pressurized to its maximum planned working pressure prior to each use. The maximum working pressure of the lowest rated component must not be exceeded. All personnel must be at a safe distance or position when pressure is applied.
- Always consult the identification band or plate on the product for the correct working pressure rating.

Warning

Working in the oil field, including at frac sites, and using high pressure equipment is inherently dangerous, and can result in **SERIOUS BODILY INJURY, DEATH, OR PROPERTY DAMAGE**.

All information contained in this catalog is general in nature. Weir does not make any representations, warranties or guarantees, express or implied, as to the accuracy or completeness of the information contained in this catalog. Weir is not liable for the user's failure to observe appropriate safety procedures.

Product availability and specifications are subject to change at any time, with or without notice.

SPM® Simplified Frac Iron

Traditional frac sites require multiple lines of iron, which increases rig-up time, labor costs, potential leak paths, pressure drop, and trip hazards. These operational challenges can stop production and compromise safety on-site.

With fewer connections, Weir's SPM® Simplified Frac Iron significantly reduces rig-up time to 3 hours or less and eliminates much of the ground iron. Its linear flow design minimizes pressure drop, and significantly reduces vibration of flow lines.

The system is available in both an all-skid modular system as well as a manifold trailer and skid configuration, each featuring a 7 1/16" 15,000 psi main line capable of providing a 123 bbl/min flow rate. The system is designed to connect directly into a zipper manifold trunk line, or an optional goathead can be installed to transition to traditional iron.

- Available with 12-station manifold trailer or 6-station manifold skids
- Optional 2-station extension is available to increase configuration to 20 stations
- Manifold skids and trailer feature robust SPM® 3" 15K Safety Iron® inlets
- Station-to-station spacing throughout manifold ranges from 7'-8'
- Total length of 18-station configuration is approximately 100-105' depending on variation

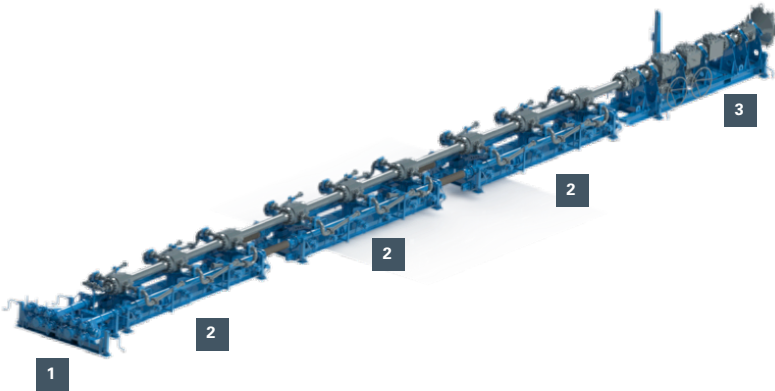

Features

- Hammer-union connections have been replaced with robust API flange connections, improving reliability while enhancing safety margins and fastener redundancy.
- Low pressure manifold comprised of schedule 80 material and low pressure manifold mounted on tracks with the ability to slide and lock in place after positioning
- Weir standard iron material spec utilized resulting in minimum strength of all pressure bearing components being 160% over the requirement in API-6A
- Skids feature manual jacks for installation alignment

- 1 Low pressure manifold skid
- 2 6-station manifold skid
- 3 Instrumentation skid with optional goathead

SPM® Instrumentation Skid

Weir's industry-first 7 1/16" 15,000 psi plug valves and check valves allow for flow line isolation and fluid directional control within the main line without needing to crossover to traditional iron.

Studded blocks on each side of the valves provide six tie in points to connect traditional frac iron components such as equalization lines, bleed off lines, relief valve systems, and transducers.

The SPM® Simplified Frac System is ideally installed directly into the trunk line of a zipper manifold, but in instances where this cannot be achieved, a goathead can be installed on the instrumentation skid. In this arrangement, the use of the 7 1/16" plug valves and check valves still eliminates need for traditional iron valves on each of the 3" lines exiting the goathead.

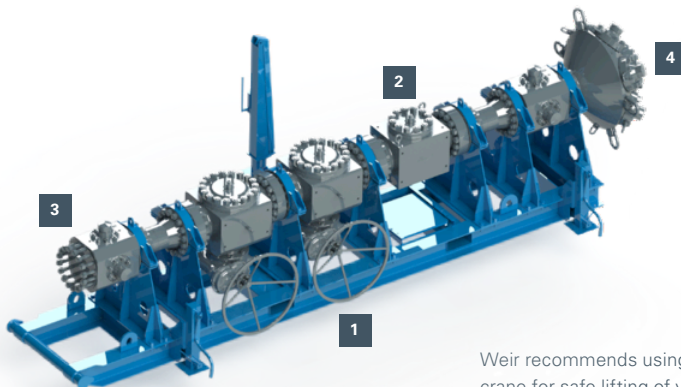

Weir recommends using an integrated hydraulic crane for safe lifting of valve caps during servicing.

- 1 SPM® 7-1/16" Plug Valves
- 2 SPM® 7-1/16" Clapper Check Valve
- 3 Studded block
- 4 Optional goathead

SPM® 7" Plug Valve

The SPM® 7" Plug Valve is the first of its kind introduced to the industry and provides reliable isolation control. The valves are installed to provide easy access to internal components, while the free-floating plug design delivers adjustment-free operations.

SPM® Plug Valves provide reliable operation with minimal maintenance. The valve requires less than 2% of the grease required during maintenance versus 7" gate valves. The valves are lighter and more compact than gate valves, and are available in both manual and hydraulic actuated configurations.

Working Temperature: API 6A PU: -20F – 250F

Compliant with API 6A Annex F PR2 validation requirements



Features

- Proprietary nickel plating process on plug for enhanced corrosion resistance
- Improved grease distribution with convenient dual-access points and channeled distribution within valve
- Traditional seal segment alignment pins replaced with interlocking cap for greater durability
- Utilizes seal segments that are preloaded to the plug through interlocking elastomer side segments to provide an initial seal between the dynamic seal surfaces to eliminate sand trapping

SPM® 7" Check Valve

Providing directional control, the SPM® 7" Check Valve utilizes a FEA optimized clapper design, which generates high contact pressures to allow for superior low and high pressure sealing.

The check valve now includes a wave spring to add preload to the top of the installed hanger, preventing vibration and unwanted movement that could affect the critical orientation of the clapper.

The SPM® 7" Check Valve has the capability to be kitted on-site and has consistently demonstrated kit life over 300 operating hours.

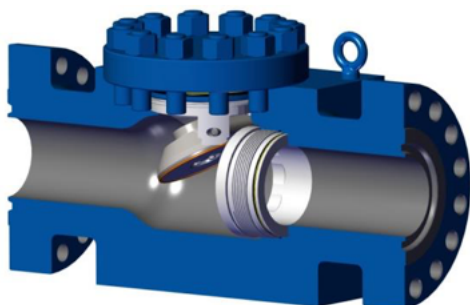

Features

- Threaded seat using o-ring and backup-ring seal combination to extend operational life of the seat prior to replacement
- The hanger and pin interface designed to maximize assembly tolerance when clapper is closed, and limit movement of the pin when the clapper is open.
- A fully enclosed pin for improved wear resistance

SPM® Swivels

SPM® Swivels are available in 2" through 4" sizes and in pressure ratings up to 15,000 psi. All SPM® Swivels feature uniform wall thickness throughout for consistent flow of fluids and extended life. Designed for optimized distribution of material for female ball race components, the ball bearing connection of SPM® Swivels are robust while providing consistent rotation. SPM® 3" 1502 Swivels and 4" 1002 Swivels are gauged during manufacturing to enable them to pass a 2.5" and 3.5" frac ball respectively.

SPM® Swivels are available in a wide variety of "styles" providing optimal performance in a variety of installations. Rotation of the swivels will vary based on configuration, with options available to provide movement in numerous planes.

NOTE: Weir's standard swivel offering is not intended for use in applications requiring continuous rotation. Contact Weir Engineering for specific information.

An insufficient number of swivels or improper make-up for a given installation can lead to unacceptable loads on the entire piping system leading to premature failure of seals or accelerated wear on the product. Swivels are not designed for side loading. Loading that will induce a bending moment into the ball races is prohibited. To prevent the above, at least three points of rotation are recommended. This will allow the swivel to accommodate the free movement of the lines in all planes. This can be accomplished at a minimum with one style-10 or two style-50 swivels turns.

It is recommended that a routine maintenance program be followed for replacement of packing and seals, and that regularly scheduled lubrication is performed.

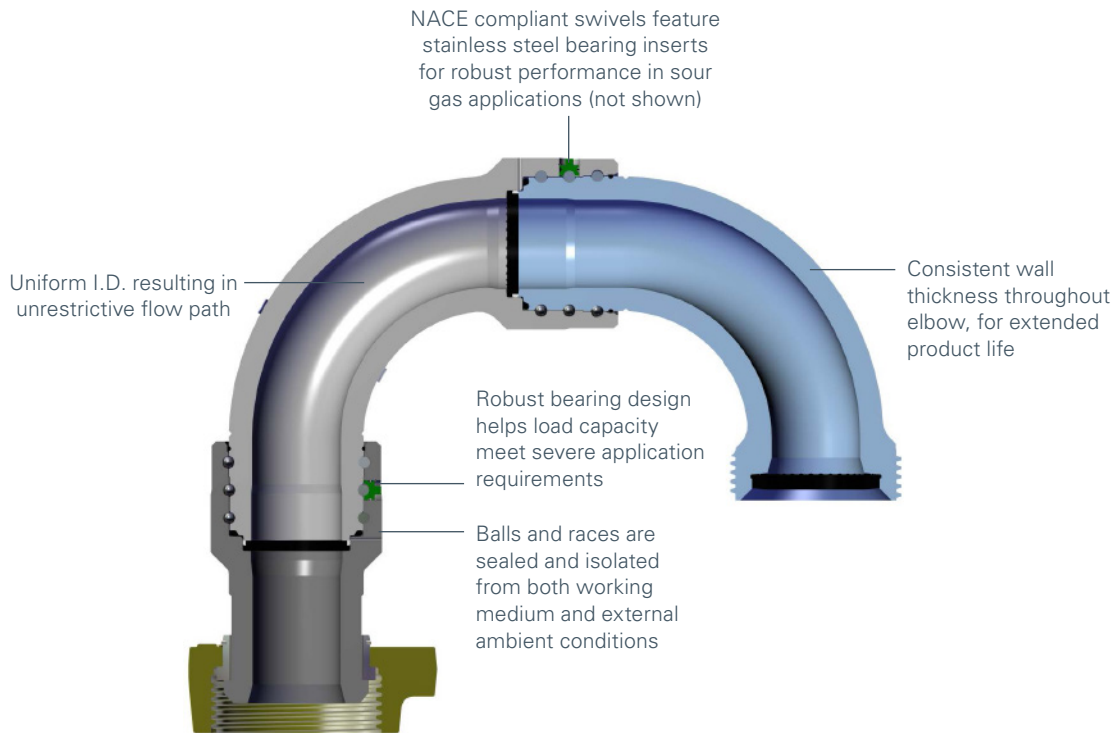

Swivel Configurations

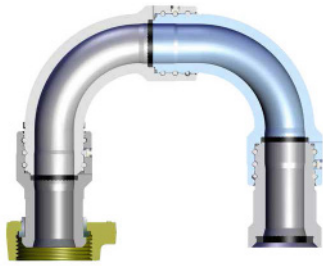

Style 10 – MxF

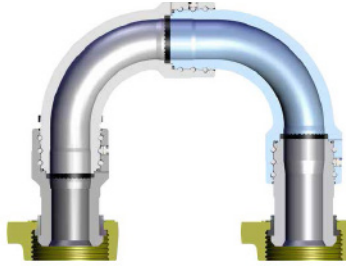

Style 10 – MxM



Style 10 – SPM® Safety Iron®

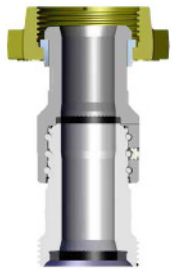

Style 20 – MxF

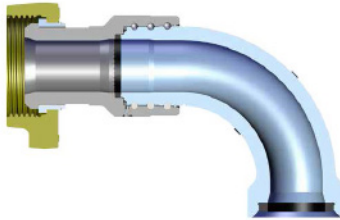

Style 30 – MxF

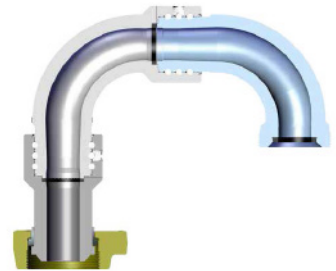

Style 50 – MxF

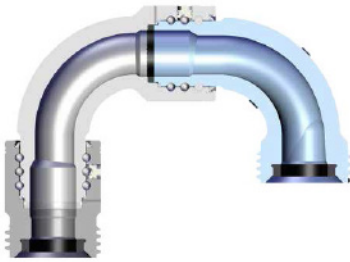

Style 50 – FxF



Style 60 – MxF



Style 60 – MxM



Style 80 – MxF

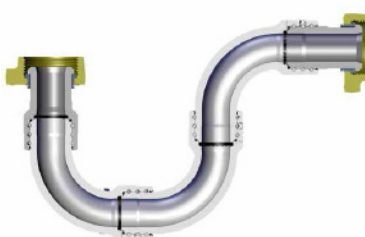

Style 100 – MxM



Style 100 – MxF

Swivel Configurations (cont.)

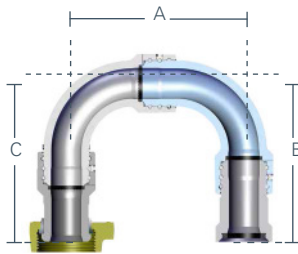

Style 10 – MxF

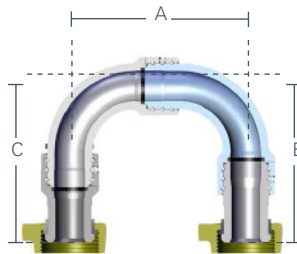

Style 10 – MxM

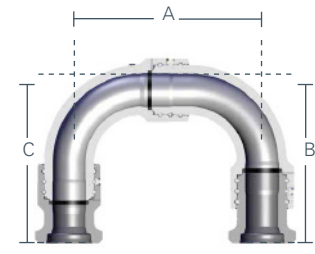

Style 10 – SPM® SafetyIron®

Style 10 Swivels

Size	End Connection	Temp	Service Type	Part Number	Dim. A (in / mm)	Dim. B (in / mm)	Dim. C (in / mm)	Inner Dia. (in / mm)	Weight (lb / kg)	Parts Kit
2"	1502M x 1502F	Low	Std.	2A17135	10.69 / 271.5	10.91 / 277.1	10.90 / 276.8	CE*	67 / 29.9	4L17126
2"	1502M x 1502M	Low	Std.	2A17205	10.69 / 271.5	10.91 / 277.1	10.90 / 276.8	CE*	77 / 34.9	4L17126
2"	15K SI x 15K SI	Low	Std.	2A17893	10.69 / 271.5	9.94 / 252.5	9.94 / 252.5	CE*	54 / 24.5	4L17126
2"	1502M x 1502F	Low	H ₂ S	2A17171	10.69 / 271.5	10.91 / 277.1	10.90 / 276.8	CE*	67 / 29.9	4L17193
2"	1502M x 1502M	Low	H ₂ S	2A17277	10.69 / 271.5	10.91 / 277.1	10.90 / 276.8	CE*	77 / 34.9	4L17193
3"	1502M x 1502F	Low	Std.	2A17920H	16.37 / 415.8	14.54 / 369.3	14.49 / 368	CE*	134 / 60.8	2A45668
3"	1502M x 1502M	Low	Std.	2A28766H	16.37 / 415.8	14.50 / 368.3	14.49 / 368	CE*	147 / 66.7	2A45668
3"	15K SI x 15K SI	Low	Std.	2A17945H	16.37 / 415.8	13.00 / 330.2	13.00 / 330.2	CE*	114 / 51.7	2A45668
3"	1502M x 1502F	Low	H ₂ S	2A17986	16.38 / 416	14.50 / 368.3	14.50 / 368.3	CE*	134 / 60.8	4L17305
3"	1502M x 1502M	Low	H ₂ S	2A17987	16.38 / 416	14.50 / 368.3	14.50 / 368.3	CE*	147 / 66.7	4L17305
4"	1002M x 1002F	Low	Std.	2A17925	18.18 / 461.8	16.19 / 411.2	17.18 / 436.4	CE*	209 / 94.8	4L17721
4"	1002M x 1002M	Low	Std.	2A17929	18.18 / 461.8	16.19 / 411.2	16.19 / 411.2	CE*	219 / 99.3	4L17721
4"	10K SI x 10K SI	Low	Std.	2A29809	18.18 / 461.8	14.50 / 368.3	14.50 / 368.3	CE*	179 / 81.2	4L17721
4"	1502M x 1502F	Low	Std.	2A17765	20.41 / 518.4	20.41 / 518.4	20.40 / 518.2	CE*	326 / 147.9	4L17785
4"	1502M x 1502M	Low	Std.	2A17737	21.20 / 538.5	20.41 / 518.4	20.41 / 518.4	CE*	352 / 159.7	4L17785
4"	15K SI x 15K SI	Low	Std.	2A17894	21.20 / 538.5	16.51 / 419.4	16.51 / 419.4	CE*	282 / 127.9	4L17785

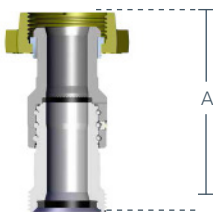

Style 10 – MxF

NOTE: Other parts or configurations may be available. Contact Weir for specific details.

NOTE: Listed weights are approximate.

NOTE: CE* – Contact Engineering for specific details.

Style 20 Swivels

Nominal Size	End Connection	Temp	Service Type	Part Number	Dim. A (in/mm)	Inner Dia. (in/mm)	Weight (lb/kg)	Parts Kit
2"	1502M x 1502F	Low	Std.	2A17271	11.12 / 282.4	CE*	31 / 14.1	4L17126
2"	1502M x 1502F	Low	H ₂ S	2A17282	11.12 / 282.4	CE*	31 / 14.1	4L17193
3"	1502M x 1502F	Low	Std.	2A17671	12.62 / 320.5	CE*	55 / 24.9	2A45668
3"	15K SI x 15K SI	Low	Std.	2A29299	9.63 / 244.6	CE*	35 / 15.9	2A45668

NOTE: Other parts or configurations may be available. Contact Weir for specific details.

NOTE: Listed weights are approximate.

NOTE: CE* – Contact Engineering for specific details.

Swivel Configurations (cont.)

SPM® Swivel Configurations

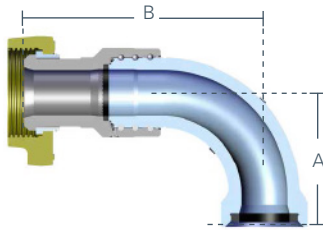

Style 30 – MxF

Style 30 Swivels

Nominal Size	End Connection	Temp	Service Type	Part Number	Dim. A (in / mm)	Dim. B (in / mm)	Inner Dia. (in / mm)	Weight (lb / kg)	Parts Kit
2"	1502M x 1502F	Low	Std.	2A17297	5.50 / 139.7	10.90 / 276.9	CE*	38 / 17.2	4L17126
2"	1502M x 1502F	Low	H ₂ S	2A17298	5.50 / 139.7	10.90 / 276.9	CE*	38 / 17.2	4L17193
3"	1502M x 1502F	Low	Std.	2A17947	8.09 / 205.5	14.49 / 368	CE*	71 / 32.2	2A45668

NOTE: Other parts or configurations may be available. Contact Weir for specific details.

NOTE: Listed weights are approximate.

NOTE: CE*– Contact Engineering for specific details.

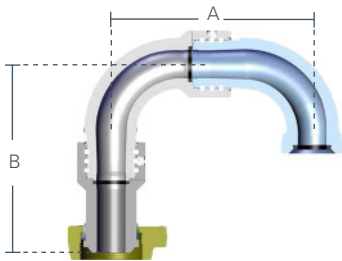

Style 50 – MxF

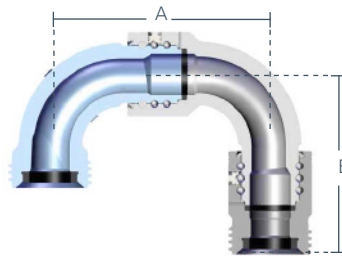

Style 50 – FxF

Style 50 Swivels

Nominal Size	End Connection	Temp	Service Type	Part Number	Dim. A (in / mm)	Dim. B (in / mm)	Inner Dia. (in / mm)	Weight (lb / kg)	Parts Kit
2"	1502M x 1502F	Low	Std.	2A17139	10.81 / 274.6	10.90 / 276.9	CE*	56 / 25.4	4L17126
2"	1502F x 1502F	Low	Std.	2A17213	10.69 / 271.5	8.80 / 223.5	CE*	43 / 19.5	4L17126
2"	1502M x 1502F	Low	H ₂ S	2A17170	10.75 / 273	10.90 / 276.9	CE*	56 / 25.4	4L17193
2"	1502F x 1502F	Low	H ₂ S	2A17279	10.69 / 271.5	8.80 / 223.5	CE*	43 / 19.5	4L17193
3"	1502M x 1502F	Low	Std.	2A17922H	16.36 / 415.5	14.50 / 368.3	CE*	111 / 50.3	2A45668
3"	1502F x 1502F	Low	Std.	2A17957	16.38 / 416	14.50 / 368.3	CE*	102 / 46.3	2A45668
3"	1502M x 1502F	Low	H ₂ S	2A17281	16.38 / 416	14.50 / 368.3	CE*	111 / 50.3	4L17305
4"	1002M x 1002F	Low	Std.	2A17926	18.18 / 461.8	16.19 / 411.2	CE*	175 / 79.4	4L17721
4"	1502M x 1502F	Low	Std.	2A17567	20.41 / 518.4	21.20 / 538.5	CE*	266 / 120.7	4L17785

NOTE: Other parts or configurations may be available. Contact Weir for specific details.

NOTE: Listed weights are approximate.

NOTE: CE*– Contact Engineering for specific details.

Swivel Configurations (cont.)

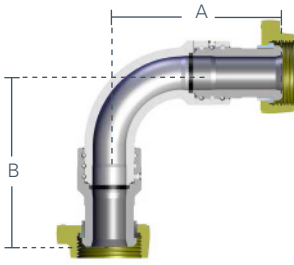

Style 60 – MxM

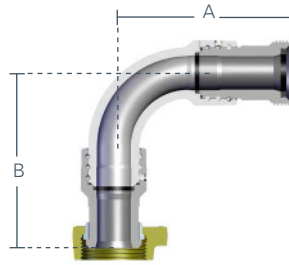

Style 60 – MxF

Style 60 Swivels

Nominal Size	End Connection	Temp	Service Type	Part Number	Dim. A (in/mm)	Dim. B (in/mm)	Inner Dia. (in/mm)	Weight (lb/kg)	Parts Kit
2"	1502M x 1502M	Low	Std.	2A17293	10.91 / 277.1	10.90 / 276.9	CE*	48 / 21.8	4L17126
2"	1502M x 1502F	Low	Std.	2A17494	10.91 / 277.1	10.90 / 276.9	CE*	36 / 16.3	4L17126
3"	1502M x 1502M	Low	Std.	2A17953	14.50 / 368.3	14.50 / 368.3	CE*	107 / 48.5	2A45668
3"	1502M x 1502F	Low	Std.	2A17969	14.50 / 368.3	14.46 / 367.3	CE*	95 / 43.1	2A45668
3"	15K SI x 15K SI	Low	Std.	2A17939	13.00 / 330.2	13.00 / 330.2	CE*	108 / 49	2A45668

NOTE: Other parts or configurations may be available. Contact Weir for specific details.

NOTE: Listed weights are approximate.

NOTE: CE*– Contact Engineering for specific details.

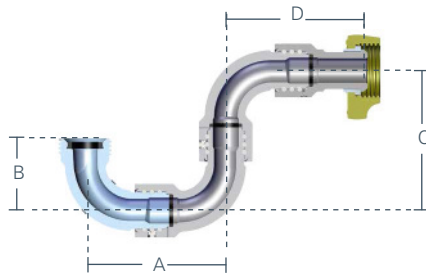

Style 80 – MxF

Style 80 Swivels

Size	End Connection	Temp	Service Type	Part Number	Dim. A (in / mm)	Dim. B (in / mm)	Dim. C (in / mm)	Dim. D (in / mm)	Inner Dia. (in / mm)	Weight (lb / kg)	Parts Kit
2"	1502M x 1502F	Low	Std.	2A17289	10.81 / 274.6	5.56 / 141.2	10.75 / 273.1	10.90 / 276.9	CE*	74 / 33.6	4L17126
3"	1502M x 1502F	Low	Std.	2A17934	16.36 / 415.5	8.09 / 205.5	16.37 / 415.8	14.49 / 368	CE*	151 / 68.5	2A45668

NOTE: Other parts or configurations may be available. Contact Weir for specific details.

NOTE: Listed weights are approximate.

NOTE: CE*– Contact Engineering for specific details.

Swivel Configurations (cont.)

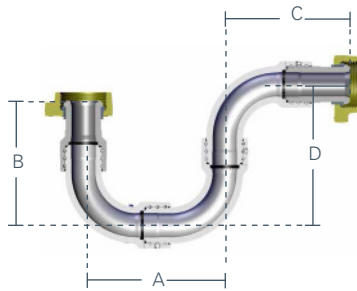

Style 100 – MxM

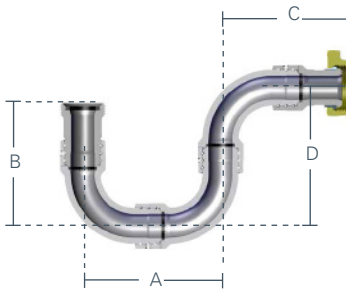

Style 100 – MxF

Style 100 Swivels

Size	End Connection	Temp	Service Type	Part Number	Dim. A (in / mm)	Dim. B (in / mm)	Dim. C (in / mm)	Dim. D (in / mm)	Inner Dia. (in / mm)	Weight (lb / kg)	Parts Kit
2"	1502M x 1502M	Low	Std.	2A17274	10.69 / 271.5	10.91 / 277.1	10.90 / 276.9	10.69 / 271.5	CE*	98 / 44.5	4L17126
2"	1502M x 1502F	Low	Std.	2A17272	10.69 / 271.5	10.91 / 277.1	10.90 / 276.9	10.69 / 271.5	CE*	85 / 38.6	4L17126
2"	1502M x 1502F	Low	H ₂ S	2A17285	10.69 / 271.5	10.91 / 277.1	10.90 / 276.9	10.69 / 271.5	CE*	85 / 38.6	4L17193
3"	1502M x 1502M	Low	Std.	2A17937	16.37 / 415.8	14.50 / 368.3	14.50 / 368.3	16.38 / 416	CE*	186 / 84.4	2A45668
3"	1502M x 1502F	Low	Std.	2A17955	16.34 / 415	14.51 / 368.6	14.46 / 367.3	16.34 / 415	CE*	174 / 78.9	2A45668
3"	15K SI x 15K SI	Low	Std.	2A17979	16.37 / 415.8	13.00 / 330.2	13.00 / 330.2	16.37 / 415.8	CE*	155 / 70.3	2A45668
3"	1502M x 1502F	Low	H ₂ S	2A17982	16.34 / 415	14.51 / 368.6	14.46 / 367.3	16.34 / 415	CE*	174 / 78.9	4L17305

Kit Contents

Parts Kit: Elastomers, swivel balls, ball plugs, plug retainer rings, grease port screw

NOTE: The swivel parts kit contains enough parts to replace the components of one articulating joint.

NOTE: Other parts or configurations may be available. Contact Weir for specific details.

NOTE: Listed weights are approximate.

NOTE: CE* – Contact Engineering for specific details.

Recommended Swivel Grease Procedure

Approved Materials

SPM® Recommended Grease P/N P45305

Procedure

1. Remove lube plug and O-ring.
2. Using a hand-held grease gun and approved grease, apply two strokes of grease.
 - a) Do not use high pressure grease gun.
 - b) Never grease swivel while under pressure.
3. Rotate swivel elbow 90 degrees.
4. Apply two more strokes.
5. Rotate assembly 90 degrees two more times and apply two strokes of grease each time.
6. Rotate swivel 360 degrees to verify smoothness of rotation.
7. Reinstall lube plug and O-ring.
8. Repeat at all articulating joints of the swivel.

Frequency

Swivel Assemblies that have been greased with P45305 only require re-greasing during servicing.

SPM® Plug Valves

SPM® Plug Valves feature quality components for dependability, minimum weight, and maximum strength.

SPM® Plug Valves act as quarter-turn isolation valves, allowing operators to isolate portions of their flow line or specific pumping units from the entire pumping system in order to address pumping, operational or maintenance requirements. The valves require minimum space, are simple to operate, exhibit a fast response, and add relatively little internal disturbance

to the flow. Pressure drop across the valve is low. SPM® Plug Valves are designed to reduce required operating torque to improve ease of use.

SPM® Plug Valves are available in sizes ranging from 1" x 2" to 4" in working pressures up to 15,000 psi. They feature precision machined and ground components, which aid in proper sealing at a wide range of operating pressures, and plating on critical areas for improved corrosion resistance.

SPM® Plug Valves are available with wheel (gear), hydraulic, or air actuators for most sizes of plug valves, which further enhances safety in the field. H₂S Plug Valves are also available and conform to NACE MR1075-90 for exposure to H₂S.

It is imperative that plug valves are routinely greased to promote proper performance and extend life. Operators should follow the greasing procedure outlined later in this document.

Warning

Turning valves under pressure should be avoided due to the inherent risks of **SEVERE BODILY INJURY, DEATH, OR PROPERTY DAMAGE**. It is recommended that remote control actuators be used for this purpose.

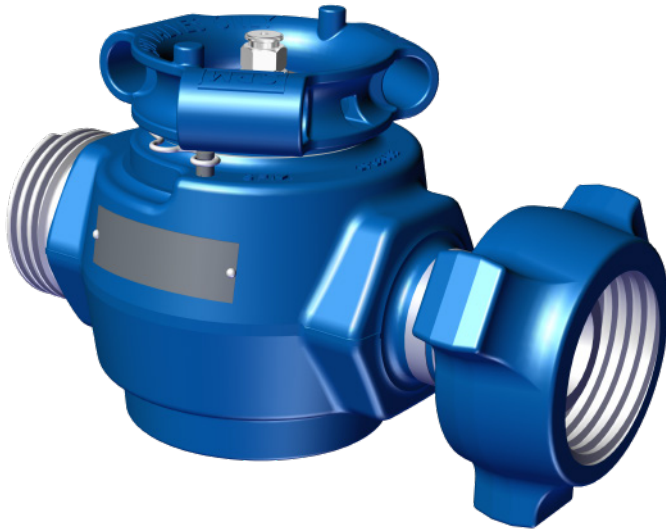

SPM® Plug Valves

1" x 2" Plug Valve

SPM® 1" x 2" Plug Valves provide reliable operation in a compact design. Suitable for pressures up to 15,000 psi, 1" x 2" plug valves are available in a manual, air, or hydraulic actuated configuration.

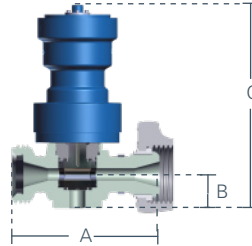
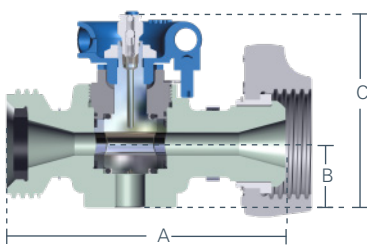
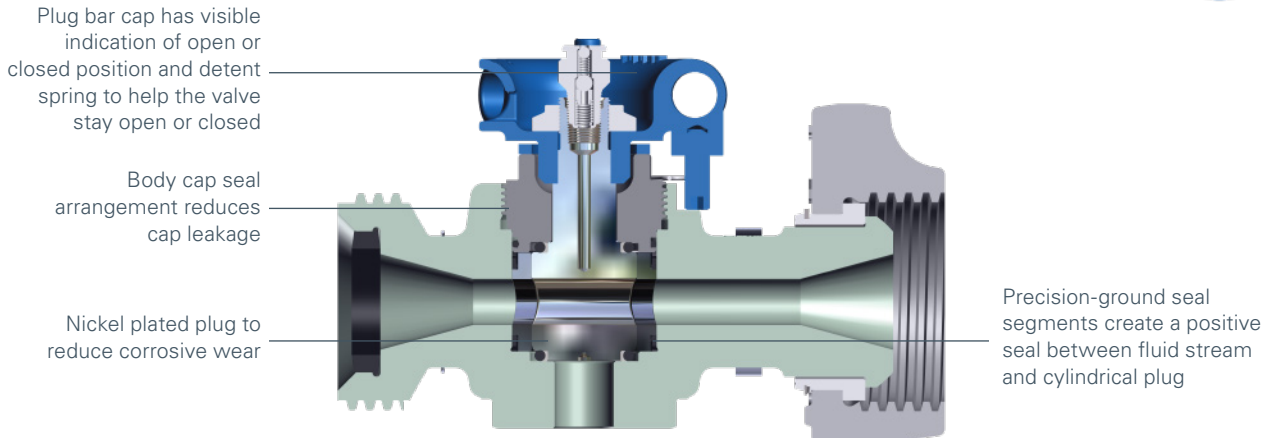
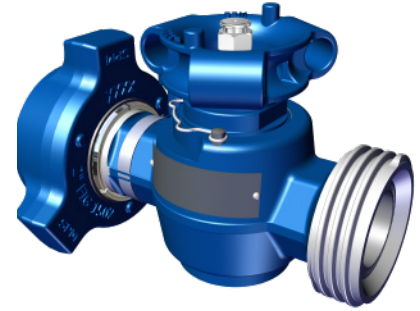

1" x 2" 1502 Plug Valve Specifications

Connection Type	Actuation	Temp	Service Type	Part Number	Dim. A (in / mm)	Dim. B (in / mm)	Dim. C (in / mm)	Inner Dia. (in / mm)	Weight (lb / kg)	Parts Kit	Elastomer Kit	Seal Kit
Hammer Union	Manual	Low	Standard	1A14483	10.56 / 268.2	2.41 / 61.2	7.28 / 184.9	0.88 / 22.4	44 / 20	4L11769	4L20947	4L14203
Hammer Union	Manual	Low	Standard (Acid Service)	1A14483V	10.56 / 268.2	2.41 / 61.2	7.28 / 184.9	0.88 / 22.4	44 / 20	4L16800	4L20949	4L16783
Hammer Union	Manual	Low	H ₂ S	1A19777	10.56 / 268.2	2.41 / 61.2	7.28 / 184.9	0.88 / 22.4	44 / 20	4L20230	4L20949	4L16783
Hammer Union	Hyd.	Low	Standard	1A14483HB	10.56 / 268.2	2.41 / 61.2	14.47 / 367.5	0.88 / 22.4	86 / 39	4L11769	4L20947	4L14203
Hammer Union	Hyd.	Low	H ₂ S	1A19777HB	10.56 / 268.2	2.41 / 61.2	14.47 / 367.5	0.88 / 22.4	86 / 39	4L20230	4L20949	4L16783
Hammer Union	Air	Low	Standard	1A14483A	10.56 / 268.2	2.41 / 61.2	16.8 / 426.7	0.88 / 22.4	64 / 29	4L11769	4L20947	4L14203
Hammer Union	No Actuator	Low	Standard	1A25037	10.56 / 268.2	2.41 / 61.2	6.29 / 159.8	0.88 / 22.4	41 / 18.6	4L11769	4L20947	4L14203

Kit Contents

Parts Kit: plug, seals, side segments, seal segments, grease fitting, backup ring

Seal Kit: seals, backup rings, grease fitting, seal segment

Elastomer Kit: seals, backup ring

NOTE: Other parts or configurations may be available. Contact Weir for specific details.

2" Plug Valve (Standard)

SPM® 2" Plug Valves are rated for pressures up to 15,000 psi. The SPM® 2" Plug Valves are available in a manual, air or hydraulic actuated configuration.

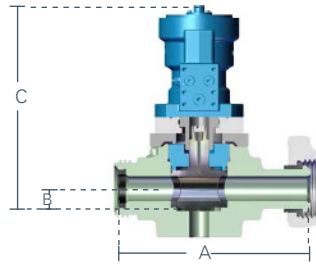
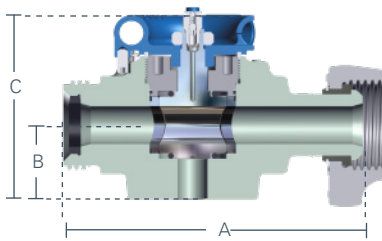
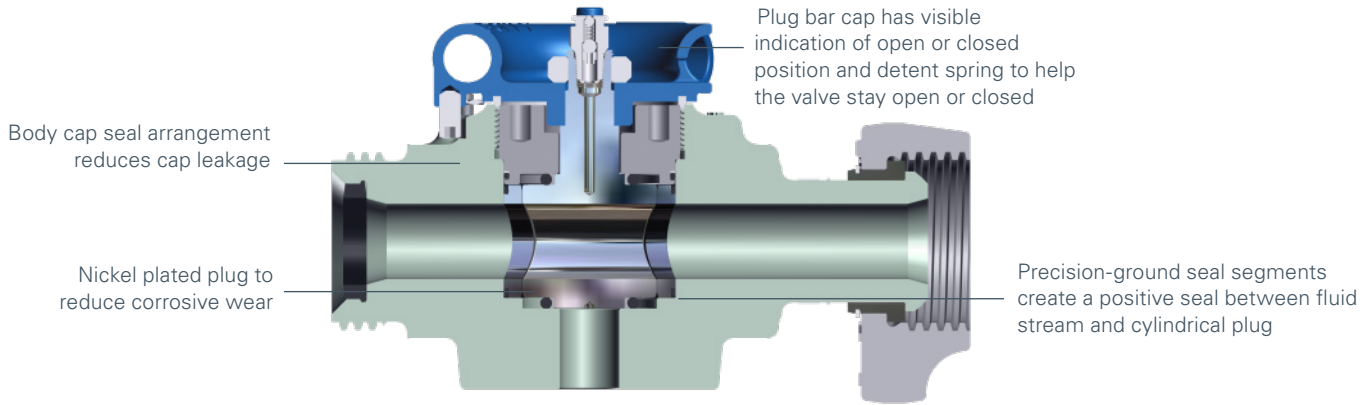
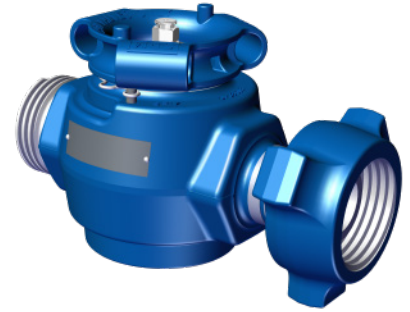

2" 1502 Plug Valve Specifications

Connection Type	Actuation	Temp	Service Type	Part Number	Dim. A (in / mm)	Dim. B (in / mm)	Dim. C (in / mm)	Inner Dia. (in / mm)	Weight (lb / kg)	Parts Kit	Elastomer Kit	Seal Kit
Hammer Union	Manual	Low	Standard	1A14487	13.88 / 352.6	3.44 / 87.4	8.88 / 225.6	1.75 / 44.5	99 / 44.9	4L11982	4L20948	4L13694
Hammer Union	Manual	Low	Std. (Acid Service)	1A20211	13.88 / 352.6	3.44 / 87.4	8.88 / 225.6	1.75 / 44.5	99 / 44.9	4L16826	4L20950	4L16824
Hammer Union	Manual	Low	H ₂ S	1A14492	13.88 / 352.6	3.44 / 87.4	8.88 / 225.6	1.75 / 44.5	99 / 44.9	4L20574	4L20950	4L20575
Hammer Union	Hydraulic	Low	Standard	1A14487HB	13.88 / 352.6	3.44 / 87.4	16.4 / 416.6	1.75 / 44.5	142 / 64.4	4L11982	4L20948	4L13694
Hammer Union	Air	Low	Standard	1A14487A	13.88 / 352.6	3.44 / 87.4	19.38 / 492.3	1.75 / 44.5	126 / 57.2	4L11982	4L20948	4L13694
Hammer Union	No Actuator	Low	Standard	1A24017	13.88 / 352.6	3.44 / 87.4	7.89 / 200.4	1.75 / 44.5	93 / 42.2	4L11982	4L20948	4L13694

Kit Contents

Parts Kit: plug, seals, side segments, seal segments, grease fitting, backup ring

Seal Kit: seals, backup rings, grease fitting, seal segment

Elastomer Kit: seals, backup ring

NOTE: Other parts or configurations may be available. Contact Weir for specific details.

NOTE: Listed weights are approximate.

2" Light Weight Plug Valve

The SPM® 2" Light Weight (LW) Plug Valve is engineered with safety in mind. The valve is designed to meet HSE lifting requirements in the North Sea while maintaining Weir's high quality standards. The SPM® 2" LW Plug Valve is rated for non-shock, cold working pressures up to 15,000 psi.

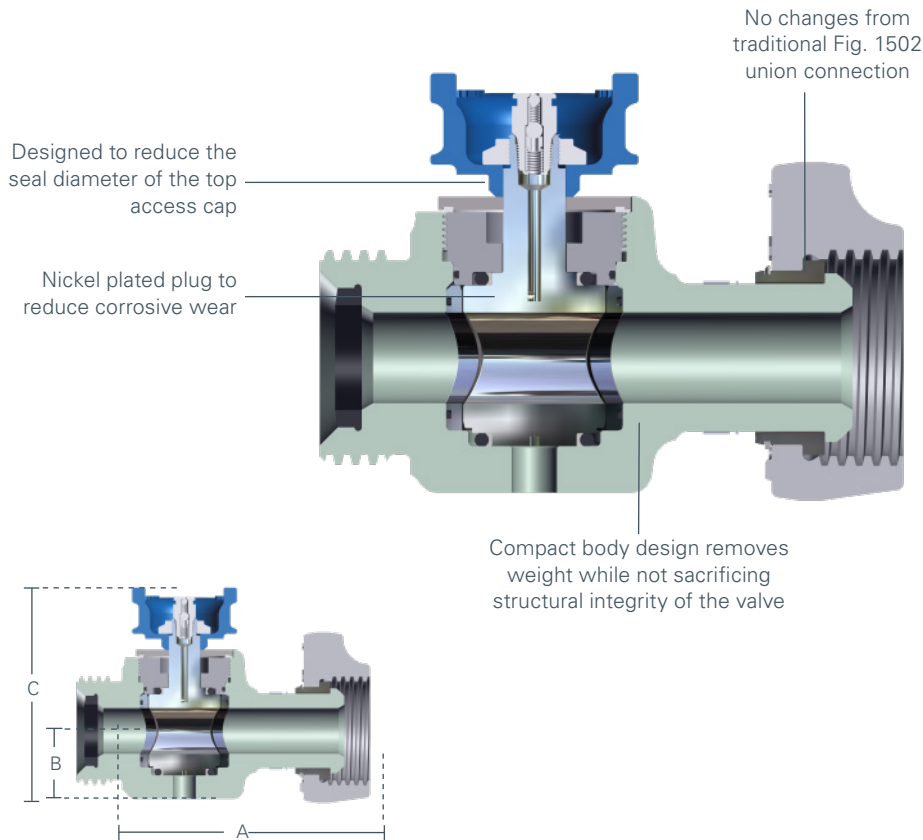

Features

- Compact/Lightweight design – weighs 51 lbs. (23.1 kg)
- Meets HSE requirements for lifting by a single individual*
- Available with DNV Certification
- CE Compliant (97/23/EC)

* HSE compliant products offer a lifting weight of 55 lbs. or less to be lifted and carried by one person.

2" 1502 Light Weight Plug Valve Specifications

Connection Type	Actuation	Temp	Service Type	Part Number	Dim. A (in / mm)	Dim. B (in / mm)	Dim. C (in / mm)	Inner Dia. (in / mm)	Weight (lb / kg)	Parts Kit	Elastomer Kit	Seal Kit
Hammer Union	Manual	Low	Standard	2A29633	10.25 / 260.4	2.60 / 66	8.08 / 205.2	1.75 / 44.5	51 / 23.1	2A30161	2A30164	2A30162
Hammer Union	Manual	Low	H ₂ S	2A36869	10.25 / 260.4	2.60 / 66	8.08 / 205.2	1.75 / 44.5	51 / 23.1	2A37146	2A37181	2A37180

Kit Contents

Parts Kit: plug, seals, side segments, seal segments, grease fitting, backup ring

Seal Kit: seals, backup rings, grease fitting, seal segment

Elastomer Kit: seals, backup ring

NOTE: Other parts or configurations may be available. Contact Weir for specific details.

NOTE: Listed weights are approximate.

3" and 4" Plug Valves

SPM® 3" and 4" Plug Valves provide reliable isolation and are available in pressure ratings as high as 15,000 psi. The valves are available in multiple actuator options, including manual in the 3", as well as wheel (gear) and hydraulic in both sizes.

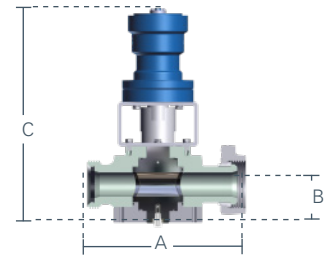
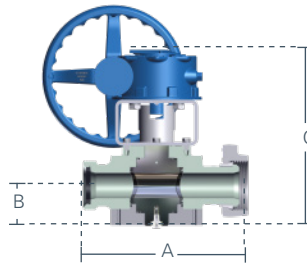
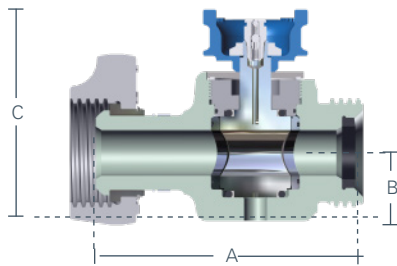
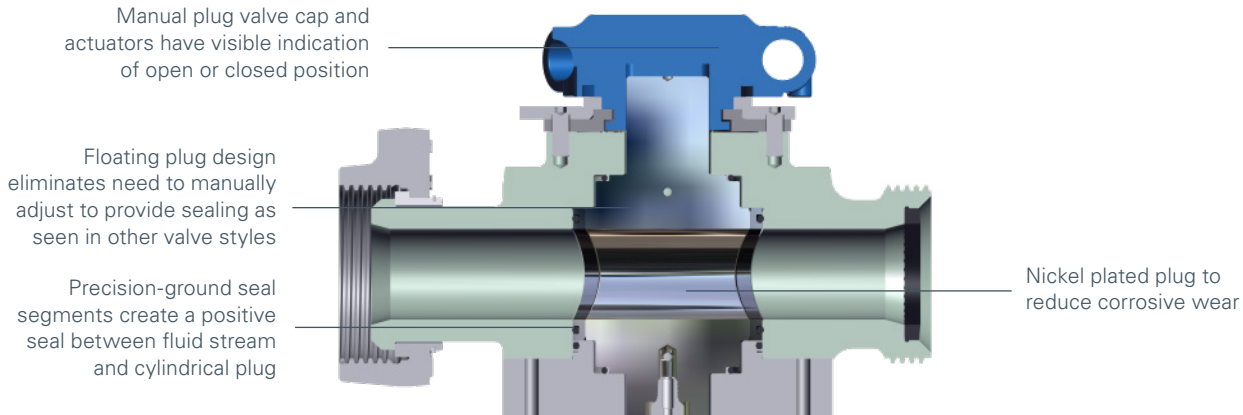

3" 1502 Plug Valve Specifications

Connection Type	Actuation	Temp	Service Type	Part Number	Dim. A (in / mm)	Dim. B (in / mm)	Dim. C (in / mm)	Inner Dia. (in / mm)	Weight (lb / kg)	Parts Kit	Elastomer Kit	Seal Kit
Hammer Union	Manual	Low	Standard	2A26611	17.00 / 431.8	4.32 / 109.7	11.83 / 300.5	2.75 / 69.8	229 / 103.9	2A39042	2A30678	2A39044
SPM® Safety Iron®	Manual	Low	Standard	2A27943	16.00 / 406.4	4.32 / 109.7	11.82 / 300.2	2.75 / 69.8	215 / 97.5	2A39042	2A30678	2A39044
Hammer Union	Gear	Low	Standard	1A14496	17.00 / 431.8	4.32 / 109.7	19.07 / 484.4	2.75 / 69.8	333 / 151	2A39042	2A30678	2A39044
SPM® Safety Iron®	Gear	Low	Standard	2A27942	16.00 / 406.4	4.32 / 109.7	19.07 / 484.4	2.75 / 69.8	320 / 145.2	2A39042	2A30678	2A39044
Hammer Union	Gear	Low	H ₂ S	1A19585	17.00 / 431.8	4.32 / 109.7	19.07 / 484.4	2.75 / 69.8	333 / 151	2A39043	2A33788	2A39045
Hammer Union	Hydraulic	Low	Standard	1A14496H	17.00 / 431.8	4.32 / 109.7	24.32 / 617.7	2.75 / 69.8	312 / 141.5	2A39042	2A30678	2A39044
Hammer Union	Hydraulic	Low	H ₂ S	1A19585H	17.00 / 431.8	4.32 / 109.7	24.32 / 617.7	2.75 / 69.8	312 / 141.5	2A39043	2A33788	2A39045
Hammer Union	Air	Low	Standard	1A14496A	17.00 / 431.8	4.32 / 109.7	22.14 / 562.4	2.75 / 69.8	257 / 116.6	2A39042	2A30678	2A39044
Hammer Union	No Actuator	Low	Standard	1A18962	17.00 / 431.8	4.32 / 109.7	10.32 / 262.1	2.75 / 69.8	200 / 90.7	2A39042	2A30678	2A39044
Hammer Union	No Actuator	Low	H ₂ S	1A20933	17.00 / 431.8	4.32 / 109.7	10.32 / 262.1	2.75 / 69.8	200 / 90.7	2A39043	2A33788	2A39045

NOTE: Other parts or configurations may be available. Contact Weir for specific details.

NOTE: Listed weights are approximate.

3" and 4" Plug Valves (cont.)

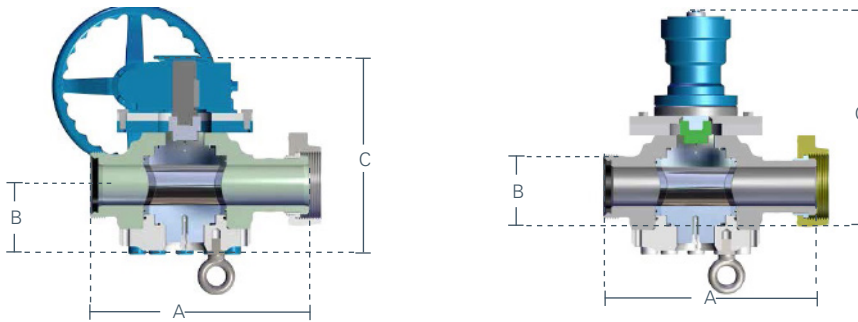

4" 1002 Plug Valve Specifications

Connection Type	Actuation	Temp	Service Type	Part Number	Dim. A (in / mm)	Dim. B (in / mm)	Dim. C (in / mm)	Inner Dia. (in / mm)	Weight (lb / kg)	Parts Kit	Elastomer Kit	Seal Kit
Hammer Union	Gear	Low	Standard	2A25182	20.50 / 520.7	5.76 / 146.3	22.71 / 576.8	3.75 / 95.3	495 / 224.5	2A26353	2A26361	2A26358
Hammer Union	Hydraulic	Low	Standard	2A25182HB	20.50 / 520.7	5.76 / 146.3	27.24 / 691.9	3.75 / 95.3	471 / 213.6	2A26353	2A26361	2A26358
Hammer Union	No Actuator	Low	Standard	2A25154	20.50 / 520.7	5.76 / 146.3	15.31 / 388.9	3.75 / 95.3	341 / 154.7	2A26353	2A26361	2A26358

NOTE: Other parts or configurations may be available. Contact Weir for specific details.

NOTE: Listed weights are approximate.

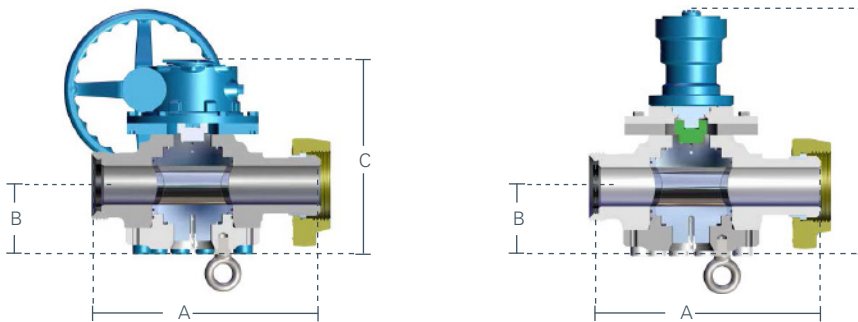

4" 1502 Plug Valve Specifications

Connection Type	Actuation	Temp	Service Type	Part Number	Dim. A (in / mm)	Dim. B (in / mm)	Dim. C (in / mm)	Inner Dia. (in / mm)	Weight (lb / kg)	Parts Kit	Elastomer Kit	Seal Kit
Hammer Union	Gear	Low	Standard	2A25168	22.13 / 562.1	5.76 / 146.3	20.70 / 525.8	3.75 / 95.3	564 / 255.8	2A26354	2A26362	2A26359
SPM® Safety Iron®	Gear	Low	Standard	2A28135	19.25 / 489	5.76 / 146.3	22.50 / 571.5	3.75 / 95.3	538 / 244	2A26354	2A26362	2A26359
Hammer Union	Hydraulic	Low	Standard	2A25168HB	22.13 / 562.1	5.76 / 146.3	27.24 / 691.9	3.75 / 95.3	540 / 244.9	2A26354	2A26362	2A26359
Hammer Union	No Actuator	Low	Standard	2A25167	22.13 / 562.1	5.76 / 146.3	15.30 / 388.6	3.75 / 95.3	410 / 186	2A26354	2A26362	2A26359

Kit Contents

Parts Kit: plug, seals, side segments, seal segments, grease fitting, backup ring

Seal Kit: seals, backup rings, grease fitting, seal segment

Elastomer Kit: seals, backup ring

NOTE: Other parts or configurations may be available. Contact Weir for specific details.

NOTE: Listed weights are approximate.

Plug Valve Grease Procedure

- Flush valve with clean water to wash away any contaminants in the valve.
- The valve must be in the open position prior to pumping the grease. Pump the operational grease, Val-Tex 972, into the valve using the grease gun.
- Cycle the valve and grease per the following criteria:
 - Pump to 2,000 psi – close and open valve
 - Pump to 4,000 psi – close and open valve
 - Pump to 6,000 psi – close and open valve

NOTE: Air will be heard “popping” during opening and closing. This will allow for a more complete filling of grease in the valve.

- Visually inspect the inside of the valve to determine if the grease is extruding around the sides of the plug.
- **For Rework Only:** Engineering requires the use of Val-Tex 1502 assembly grease when disassembly and rebuild of the valve is required. Completely coat with grease the O.D. of the plug and seal segments. Reassemble valve using new seal components.

NOTE: The mixing of operational grease types/brands is not recommended. Grease mixing can result in a decrease of valve performance and/or increase the required regreasing frequency.

Weir recommends operational re-greasing at a minimum after every six stages or six valve turn operations.

SPM® Check Valves

Available in both clapper style and dart style, SPM® Check Valves are placed in the treating line to allow flow to the well but isolate any back flow to go upstream of the valve. This provides protection for equipment at various locations in the flow line by helping to prevent fluid from traveling back up into the manifold area or into the pumps. Two flow directional configurations are offered, including wing-ahead (standard flow) or thread-ahead (reverse flow) models.

Weir recommends that clapper check valves be used in applications in which fluid being pumped contains solid materials, such as proppant. Dart check valves are recommended only for use in non-abrasive media applications, such as nitrogen pumping.



Warning

Before assembly into a fluid line, check the direction of flow indicated by the arrow on the body of the valve and make sure the valve is properly oriented in the flow line. Improperly oriented check valves will shut off fluid flow, causing an over pressure event that can result in **SERIOUS BODILY INJURY, DEATH, OR PROPERTY DAMAGE.**

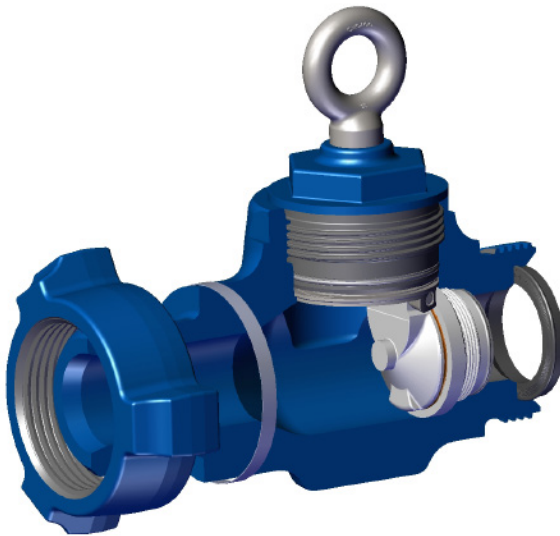

SPM® Clapper Style Check Valves

SPM® Clapper Style Check Valves are manufactured in 2", 3", and 4" sizes for operating pressures up to 15,000 psi. Check valves with hammer union end connections are available in standard or reverse flow, and should be installed with the flow direction arrow machined on the body aligned with the flow direction of the line. Versions with SPM® Safety Iron® connections are available in only one part number, and only need to have the directional arrow on the body aligned with the flow direction of the treating line. The clapper check valves, unlike the dart style, are designed for fluids that are heavily laden with materials such as proppants, solids, and ball sealers.

The valve should be mounted in-line in a flat, horizontal position to allow for gravity to close the clapper when there is no flow. The clapper will close by itself, reseat, and seal when sufficient back pressure is encountered. The valve should be mounted such that the bottom plane of the valve (normal to the gravitational direction) does not exceed 22 degrees.

SPM® Clapper Style Check Valves are intended to provide quick responding directional fluid control. For complete fluid shut-off, an isolation valve (i.e., the SPM® Plug Valve) should be installed in series with the SPM® Clapper Style Check Valve. Do not attempt to work on or repair any equipment isolated by the clapper check valve while the check valve has pressurized fluid behind it.

SPM® EXL 3" Clapper Style Check Valves

The EXL check valve utilizes unique design features resulting in improved reliability and performance compared to other check valves currently available to the market.

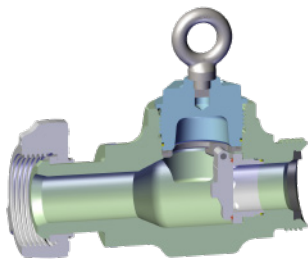

Standard Flow

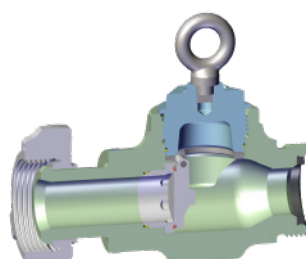

Reverse Flow

3" 1502 EXL Clapper Check Valve Specifications

Size	Connection Type	Outlet/Branch Config	Temp	Service Type	Part Number	Dim. A (in / mm)	Dim. B (in / mm)	Inner Dia. (in / mm)	Weight (lb / kg)	Parts Kit
3"	FxM (Standard Flow)	Hammer Union	Low	Std.	2A43982	16.00 / 406.4	14.60 / 370.8	2.75 / 69.8	125 / 56.7	2A44825
3"	MxF (Reverse Flow)	Hammer Union	Low	Std.	2A43980	16.00 / 406.4	14.60 / 370.8	2.75 / 69.8	125 / 56.7	2A44825
3"	SPM® Safety Iron®	SPM® Safety Iron®	Low	Std.	2A43974	13.13 / 333.5	14.60 / 370.8	2.75 / 69.8	102 / 46.3	2A44825

SPM® EXL Features and Designs

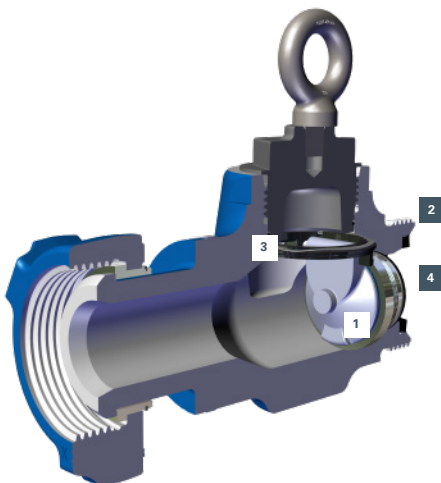

1 Clapper

- Clapper features proprietary urethane seal to extend life and improve sealing
- Hardened stainless steel clapper for increased resistance to erosion
- Integral hard stop to eliminate compressive damage
- Fully enclosed pin for improved wear resistance

2 Hanger

- Unique interface between hanger and oversized tungsten carbide steel pin limits pin movement resulting from fluid flow, extending life
- Hanger and pin interface designed to maximize assembly tolerance
- Reduces excessive clapper / hanger pin movement

3 Wave Spring

- Included to add preload to the top of the installed hanger to prevent vibration and unwanted movement.

4 Seat

- New seat features O-ring and backup-ring seal combination to enhance sealing performance and extend operational life
- Low profile machined feature on seat face to facilitate easier removal
- Seat kit components will not be sold separately. The o-ring and back-up ring should always be replaced when the seat is removed.
- Seats should only be replaced when the valve will not pass pressure test due to leaking past the seat or observed erosion on the seat face.



SCAN ME

Demonstration of the proper disassembly, inspection and reassembly of the SPM 3" Clapper Style EXL Check Valve.

Warning

Before assembly into a treating line, check the direction of flow indicated by the arrow on the body of the valve and make sure the valve is properly oriented in the flow line. Improperly oriented check valves will shut off fluid flow, which may result in an over pressure event that can cause **SERIOUS BODILY INJURY, DEATH, OR PROPERTY DAMAGE.**

SPM® 2" and 4" Clapper Check Valves

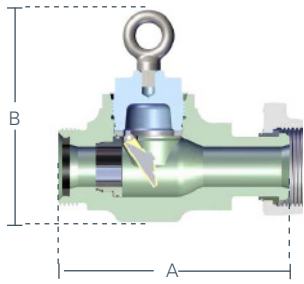

Standard Flow Shown

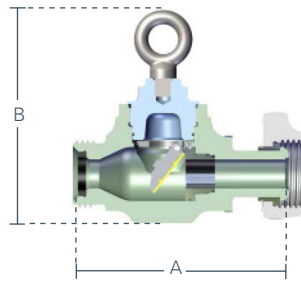

Reverse Flow Shown

2" 1502 Clapper Check Valve Specifications

Size	Connection Type	Outlet/Branch Config	Temp	Service Type	Part Number	Dim. A (in / mm)	Dim. B (in / mm)	Inner Dia. (in / mm)	Weight (lb / kg)	Parts Kit
2"	FxM (Standard Flow)	Hammer Union	Low	Std.	2A29018	13.13 / 333.5	13.00 / 330.2	1.75 / 44.5	75 / 34	2A29092
2"	MxF (Reverse Flow)	Hammer Union	Low	Std.	2A29024	13.13 / 333.5	13.00 / 330.2	1.75 / 44.5	75 / 34	2A29092
2"	FxM (Standard Flow)	Hammer Union	Low	H ₂ S	2A29022	13.13 / 333.5	13.00 / 330.2	1.75 / 44.5	75 / 34	2A29093
2"	MxF (Reverse Flow)	Hammer Union	Low	H ₂ S	2A29026	13.13 / 333.5	13.00 / 330.2	1.75 / 44.5	75 / 34	2A29093

NOTE: Other parts or configurations may be available. Contact Weir for specific details.

NOTE: Listed weights are approximate.

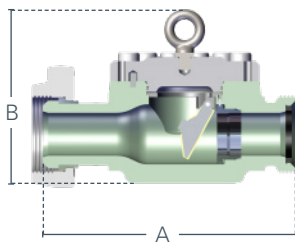

Standard Flow Shown

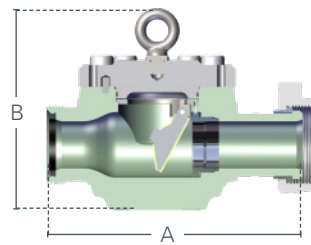

Reverse Flow Shown

4" 1002 and 4" 1502 Clapper Check Valve Specifications

Size	Connection Type	Outlet/Branch Config	Temp	Service Type	Part Number	Dim. A (in / mm)	Dim. B (in / mm)	Inner Dia. (in / mm)	Weight (lb / kg)	Parts Kit
4" 1002	FxM (Standard Flow)	Hammer Union	Low	Std.	2A28744	20.48 / 520.2	16.11 / 409.2	3.75 / 95.3	340 / 154.2	2A33163
4" 1002	MxF (Reverse Flow)	Hammer Union	Low	Std.	2A28949	20.48 / 520.2	16.11 / 409.2	3.75 / 95.3	340 / 154.2	2A33163
4" 1502	FxM (Standard Flow)	Hammer Union	Low	Std.	2A28742	22.13 / 562.1	15.16 / 385.1	3.75 / 95.3	393 / 178.3	2A33163
4" 1502	MxF (Reverse Flow)	Hammer Union	Low	Std.	2A28945	22.13 / 562.1	15.16 / 385.1	3.75 / 95.3	393 / 178.3	2A33163
4" 15K	SPM® Safety Iron®	SPM® Safety Iron®	Low	Std.	2A28959	19.25 / 489	15.16 / 385.1	3.75 / 95.3	368 / 166.9	2A33163

Kit Contents

Parts Kit: clapper, pins, hanger, seal, backup ring

NOTE: Other parts or configurations may be available. Contact Weir for specific details.

NOTE: Listed weights are approximate.

Dart Style Check Valve

The SPM® Dart Style Check Valve permits fluid to flow towards the well, while impeding back flow from traveling upstream of the check valve. The valve acts as an independent pressure actuated response system, working immediately following a pressure loss and requiring no operator to be present for initiation.

The SPM® Dart Style Check Valve is constructed of a two-piece body that houses an inline spring loaded dart. When fluid enters from the inlet side, it will overcome the low spring force on the dart. The dart will travel away from the inlet and allow the fluid to flow around towards the outlet. When fluid flow stops, the light spring force closes the dart against its seat, helping to prevent fluid from flowing back through the flow line.

Dart valves are intended for use in services where the fluid media does not contain abrasive materials. For those applications, the SPM® Clapper Check Valve will provide enhanced performance and extended life.



Warning

Before assembly into a fluid line, check the direction of flow indicated by the arrow on the body of the valve and make sure the valve is properly oriented in the flow line. Improperly oriented check valves will shut off fluid flow, causing an over pressure event that can result in **SERIOUS BODILY INJURY, DEATH, OR PROPERTY DAMAGE.**



Arrow on body indicates suitable flow direction for correct installation in flow lines

Dart Style Check Valve (cont.)

The SPM® Dart Style Check Valve should be installed in a branch where a flow control device is necessary to prevent flow in one direction. For complete fluid shut-off, an isolation valve (such as the SPM® Plug Valve) should be installed in series with the SPM® Dart Check Valve. The SPM® Dart Valve is not required to be mounted flat to function properly. The internal spring constantly applies light pressure on the dart that prevents any effect gravity might have on the dart's operation.

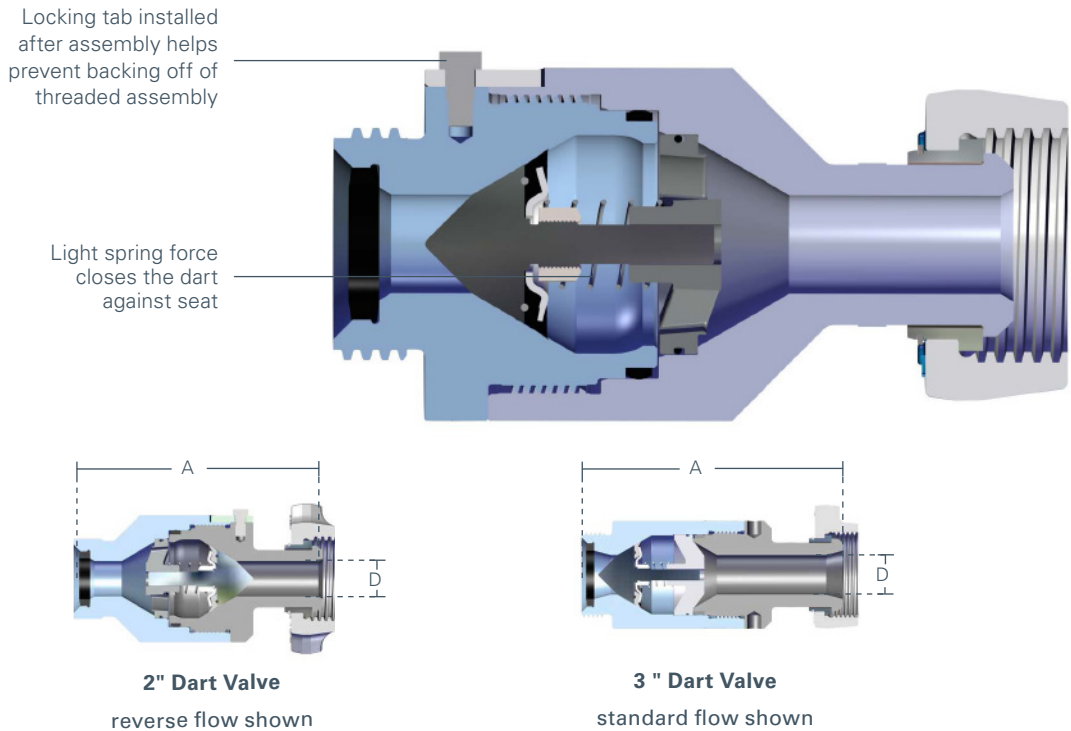

Dart Valve Specifications

Size	Flow Configuration	Connec-tion Type	Temp	Service Type	Seal Type	Part Number	Dim. A (in / mm)	Inner Dia. (in / mm)	Weight (lb / kg)	Parts Kit	Dart Kit	Seal Kit
2"	1502F x 1502M (Standard Flow)	Hammer Union	Low	Std.	Standard	1A19662C	12.06 / 306.3	1.75 / 44.5	63 / 28.6	4L20823C	4L19959	4L20828C
2"	1502M x 1502F (Reverse Flow)	Hammer Union	Low	Std.	Standard	1A19660C	12.23 / 310.6	1.75 / 44.5	63 / 28.6	4L20823C	4L19959	4L20828C
2"	1502F x 1502M (Standard Flow)	Hammer Union	Low	Std.	Metal to Metal	1A23085CLT	12.06 / 306.3	1.75 / 44.5	63 / 28.6	4L23935C	4L19959	4L20828C
2"	1502M x 1502F (Reverse Flow)	Hammer Union	Low	Std.	Metal to Metal	1A24137C	12.23 / 310.6	1.75 / 44.5	63 / 28.6	4L23935C	4L19959	4L20828C
2"	1502F x 1502M (Standard Flow)	Hammer Union	Low	H ₂ S	Standard	1A19467C	12.06 / 306.3	1.75 / 44.5	63 / 28.6	4L20824C	4L18824	4L20829C
2"	1502M x 1502F (Reverse Flow)	Hammer Union	Low	H ₂ S	Standard	1A19485C	12.06 / 306.3	1.75 / 44.5	113 / 51.3	4L20824C	4L18824	4L20829C
3"	1502F x 1502M (Standard Flow)	Hammer Union	Low	Std.	Standard	1A19843C	16.56 / 420.6	2.50 / 63.5	113 / 51.3	4L20825C	4L18821	4L20830C
3"	1502M x 1502F (Reverse Flow)	Hammer Union	Low	Std.	Standard	1A19845C	16.53 / 419.9	2.50 / 63.5	113 / 51.3	4L20825C	4L18821	4L20830C
3"	1502M x 1502F (Standard Flow)	Hammer Union	Low	Std.	Standard	1A18614C	16.38 / 416	2.50 / 63.5	113 / 51.3	4L20825C	4L18821	4L20830C

Kit Contents

Parts Kit: dart, seals, nut, spring, stop, screw, key

Seal Kit: dart, seals, spring, nut

Elastomer Kit: seals

NOTE: Other parts or configurations may be available. Contact Weir for specific details.

NOTE: Listed weights are approximate.

SPM® Relief Valves

In the pressure pumping industry, there is an inherent level of danger surrounding treating lines operating at high pressures. The potential for over pressure events exists, which could result in catastrophic failure of the treating line and result in **SERIOUS BODILY INJURY, DEATH, OR PROPERTY DAMAGE**. In order to avoid this type of failure, relief valves are commonly used on pressure pumping sites. Relief valves function by relying on the system's hydraulic pressure to overcome a preset force in the valve, which then expels fluid through an outlet. Weir offers a variety of relief valve styles to help protect against over pressurization.

Weir offers relief valves in two primary types: spring operated and nitrogen operated. All of these valves are intended for emergency pressure relief for most well service applications. They are designed for operating temperatures from -30°C to $+110^{\circ}\text{C}$ (-22°F to $+230^{\circ}\text{F}$). They are not suitable for fire protection and they are not intended for continuous flow.

All of these valves are designed for liquid flow. Acceptable media include cement, acidizing fluids, fracturing fluids, and drilling muds. Some of the product is rated for sour gas service—be sure to consult with Weir Engineering for H_2S or other special services.



3" Spring Actuated Relief Valve



3" EXL N2 Back Pressure Relief Valve

Spring Style Relief Valve

SPM® Spring Actuated Relief Valves are direct acting, relying on the system’s hydraulic pressure to open when the preset force of the spring is exceeded. The 2” valve’s operation is a simple balance between the spring loaded keeper which holds the ball in the seat and the inlet liquid pressure acting on the ball. The spring pressure is set by tightening the hex bolt on top which pushes on the keeper, and, in turn, compresses the Belleville springs that force the keeper on the ball. When the inlet fluid pressure rises and overcomes the set spring pressure, the ball is lifted off its seat thereby discharging fluid through the outlet end. Once the pressure of the inlet fluid falls below the set spring pressure, the ball will be pushed back onto its seat and the fluid can pass downstream.

Weir offers multiple relief valve spring configurations, each optimized for a specific pressure range. Using a valve within the rated pressure range will likely achieve greater discharge capacity and improved repeatability. It is recommended that the valve is sized according to the maximum set pressure that may be required. This approach will help prevent the valve from being used at set pressures greater than the recommended value.

Approximate Max Discharge Rate for Relief Valves

- 2” Spring – 150 gpm maximum
- 3” Spring – 430 gpm maximum

As discharge requirements increase, multiple valves may be preferred, and are permissible. Multiples of either size valve is allowed as long as the valves are all set within 10% of each other.

Warning

This device is intended to discharge to atmospheric pressure when it relieves. It should not have its discharge port blocked or be subject to any back pressure while in the closed position. Failure to comply may lead to **SERIOUS BODILY INJURY, DEATH, OR PROPERTY DAMAGE.**

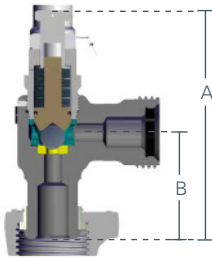
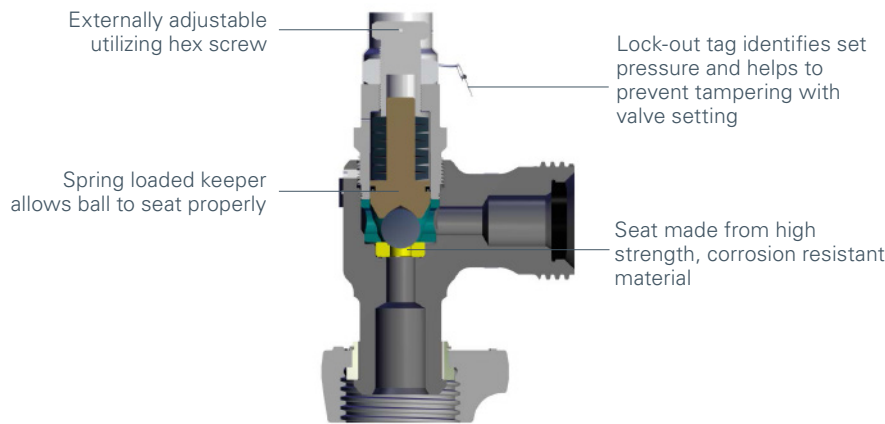

2” Spring Relief Valve

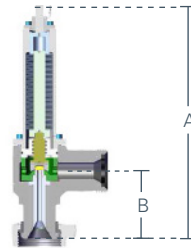

3” Spring Relief Valve

Spring Relief Valve Specifications

Size	Connection Type	Outlet/ Branch Configuration	Temp	Service Type	Part Number	Dim. A (in / mm)	Dim. B (in / mm)	Weight (lb / kg)	Parts Kits	Ball, Seat & Seal Kit	Gate, Nozzle & Seal Kit	Seal Kit
2"	Hammer Union	2" LPTL F Outlet	Low	Std.	2A18138	13.01 / 330.5	6.06 / 153.9	41 / 18.6	4L20418	4L18755		4L20423
2"	Hammer Union	2" 1502F Outlet	Low	Std.	2A18192	13.01 / 330.5	6.06 / 153.9	47 / 21.3	4L20418	4L18755		4L20423
2"	Hammer Union	2" 1502F Outlet	Low	H ₂ S	2A18544	13.01 / 330.5	6.06 / 153.9	47 / 21.3	4L20420			4L20424
2"	Hammer Union	2" 2002F Outlet	Low	Std.	2A18796	13.06 / 331.7	6.06 / 153.9	46 / 20.9	4L20422	4L19186		4L20426
3"	Hammer Union	3" 1502F Outlet	Low	Std.	2A22356	30.83 / 783.1	8.44 / 214.4	167 / 75.7	4L22486		4L22481	4L22482

Kit Contents

Parts Kit: 2” – ball, seat, spider, spring, seals, screw, nut
 3” – keeper, gate, nozzle, spider, seals

Ball, Seat & Seal Kit: ball, seat, seal

Gate, Nozzle & Seal Kit: gate, nozzle, seal

Seal Kit: seals

NOTE: Other parts or configurations may be available. Contact Weir for specific details.

NOTE: Listed weights are approximate.

Nitrogen Style Relief Valves

Weir offers two styles of Nitrogen relief valves, the SPM® EXL Back Pressure Valve and the SPM® Full Bore Unloading Valve. Compact and simple to operate, the valves are direct acting, relying on the system's hydraulic pressure to overcome a preset nitrogen gas force to relieve system pressure.

EXL Back Pressure Relief Valve

With its enhanced internal geometry, unique sealing components, and robust forging, the SPM® EXL Back Pressure Relief Valve can reduce safety risk for the operator while improving efficiencies through reduced downtime and lower maintenance costs. Unlike full open relief valves, which require a substantial pressure drop before reseating, this valve has the capability to reseal near the sequencing pressure. This, in turn, allows for uninterrupted pumping stages and equates to less downtime and improved production.

The SPM® EXL Back Pressure Relief Valve should be installed in a branch on the high-pressure treating line. It is recommended that the valve be placed downstream away from the high pressure pumps. This increased distance will reduce the likelihood of the valve seat experiencing "chatter" as a result of pulsation in the treating line.

However, localized protection for pumps on site is permissible. Contact Weir for more information. The valve should be operated in the upright position. This will reduce the tendency for proppants to accumulate around the sealing area and potentially affect the sealing performance.

The approximate flow rate for the EXL Relief Valve is 2,000 gpm. This value is intended to be referenced for general sizing purposes. The actual discharge capacity is dependent on pressure differential and type of fluid media being discharged. Please contact Weir Engineering for specific information.

NOTE: The valve should be set at a minimum of 1,000 psi above system operating pressure.

Warning

This device is intended to discharge to atmospheric pressure when it relieves. It should not have its discharge port blocked or be subject to any back pressure while in the closed position. Failure to comply may lead to **SERIOUS BODILY INJURY, DEATH, OR PROPERTY DAMAGE.**



Features

- Enhanced internal geometry results in reduced turbulence and sand accumulation in the valve
- Newly designed packing assembly and updated cylinder rod design improve sealing capabilities during normal cycling of the valve
- Threaded body to bonnet configuration incorporates a robust design margin to allow for safe operations in the event of an obstructed discharge port
- Support/transport stand available upon request

Full Bore Unloading Valve

Unlike the SPM® EXL Back Pressure Relief Valve, the SPM® N₂ Full Bore Unloading Valve operates as a dump valve, remaining open until the pump system is shut down and the valve is reset. It is recommended for those operators who want full system shutdown after an overpressure event has occurred.

By opening fully when sequenced, back pressure drops drastically once it opens. Consequently very large amounts of flow can pass through this valve. It is externally adjustable from a pressure of 1,000 psi to the maximum setting.

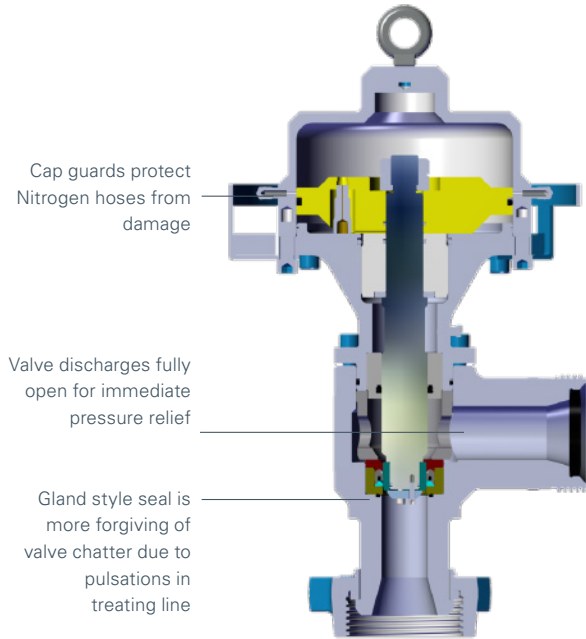

Full Bore Unloading Valve

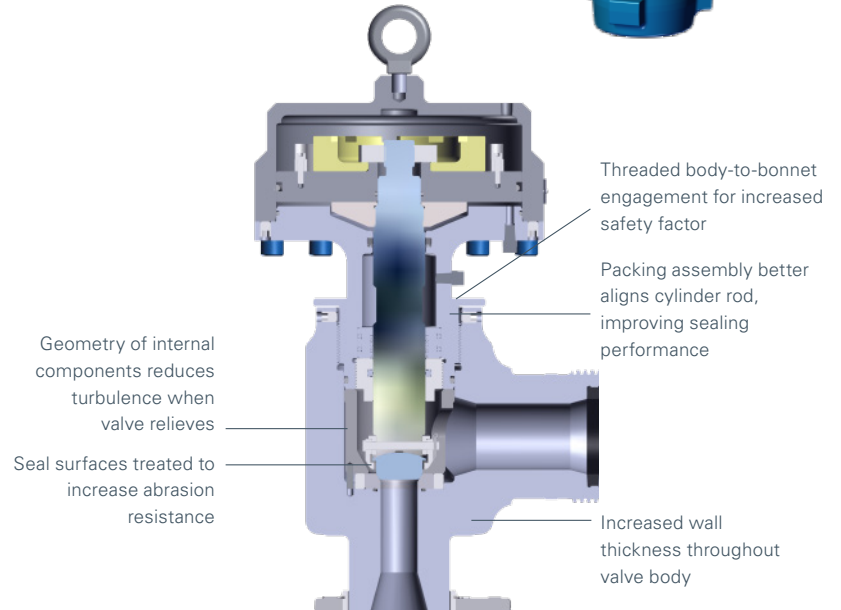

EXL Back Pressure Relief Valve

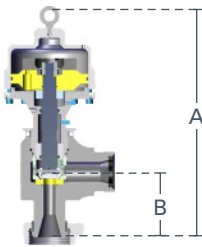

EXL Back Pressure

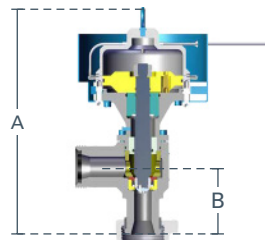

Full Bore Unloading

Nitrogen Relief Valve Specifications

Valve Type	Inlet Connection	Outlet/ Branch Configuration	Temp	Service Type	Part Number	Dim. A (in / mm)	Dim. B (in / mm)	Weight (lb / kg)	Parts Kits	Body Assy*
Nitrogen – Unloading	3" 1502M	3" 1502F	Low	Std.	1A23392	28.22 / 716.8	15.46 / 392.7	250 / 113.4	4L23547	4L24315
Nitrogen – EXL Back Pressure	3" 1502M	3" 1502F	Low	Std.	2A33687 (no regulators)	29.21 / 741.9	14.31 / 363.5	231 / 104.8	2A37213	
Nitrogen – EXL Back Pressure	3" 1502M	3" 1502F	Low	Std.	2A40306 (w/regulators)	29.21 / 741.9	14.31 / 363.5	231 / 104.8	2A37213	

Kit Contents

Parts Kit: (EXL Back Pressure) gate, nozzle, bushing, wiper rod, springs, seals and pins

Parts Kit: (Unloading) wear sleeve, nozzle, cartridge, spider, sleeve, seals, backup rings

NOTE: Other parts or configurations may be available. Contact Weir for specific details.

NOTE: Listed weights are approximate.

NOTE: Replacement body vessel tested before shipment

Legacy Back Pressure N₂ Valve

In order to continue to support the legacy SPM® Nitrogen Back Pressure Relief Valves offered prior to the SPM® EXL Relief Valve, the below kit is still available.

Type Kit	Size	Part Kit
Valve Assembly	3" 1502	1A23493LT
Parts Kit	3" 1502	4L24315

Relief Valve Stand Assemblies

Weir recommends that all relief valve and isolation valve assemblies be supported by a self-enclosed portable structure that has been specifically engineered for the valve. Failure to comply with this requirement may expose adjacent union connections to excessive loading, resulting in potential premature failure and line separation, which may cause **SERIOUS BODILY INJURY, DEATH, OR PROPERTY DAMAGE.**

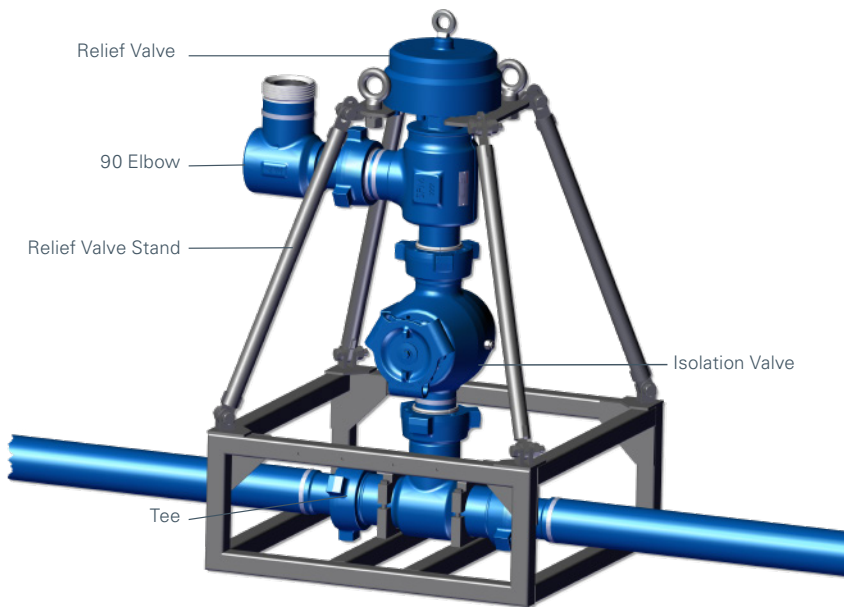

Common Installation Setup

(contact Engineering for specific configurations)

SPM® SafeEdge™ Automated Relief Valve Control (ARC) System

The SPM® SafeEdge™ ARC intelligent valve system from Weir allows customers to remotely set and control a high-speed pressure relief valve while monitoring treating-line pressure, helping to prevent over-pressuring of treating iron. Through monitoring and autonomous reporting, the intelligent N₂ valve reduces non-productive time. More compact than the previous generation, it comes with a network infrastructure built into a rugged field case that enables the operator to connect to the Datavan via wired or wireless connection, allowing system control through a webpage on any kind of Wi-Fi-capable device. In the case of a pressure-relief event, the system automatically logs high-speed data locally. It also will publish this data to a secure web portal.

Thanks to intelligent control of relief valve, the wellsite can relieve pressure faster than the alternative systems currently available. Those utilizing hydraulic systems to actuate plug valves are slower to react and rely heavily on multiple components all functioning correctly. The design reduces the amount of N₂ consumption and also improves the N₂ valve sealing surface life and performance.

The SPM® SafeEdge™ ARC offers quick resetting—no full shutdown required. The user-friendly interface contains visual and verbal warnings indicating low nitrogen input, lost system pressure, or loss of power, along with other criteria. In instances where manual shutdown becomes necessary, there's an emergency trip switch on the user interface to manually open the relief valve.



Assembly #: 2A44778
Description: ASSY/ARC 2.0/SNGL VA

Features

Capability

- Durable hardware with temperature-compensating E-regulator to eliminate early or late pop-off events
- Adjustable reset/pop-off filter
- Self-diagnostic and remote inspection
- Single-system control of two N₂ valves with two different set pressures
- GPS/satellite/cellular hardware built-in

Data

- Pop-off event will capture high-speed data 30 seconds before and after event
- System creates log files that store data every 12 hours that can be opened in Microsoft Excel
- Data can be saved to removable flash drive or accessed through a remote website
- .csv stream out capable through TCP/IP
- Ability to record data feature can be turned ON or OFF

Efficiency

- Improved performance and life of N₂ pop-off valve sealing components
- Reduces typical nitrogen consumption

SPM® EXL Pressure Relief Disc

Weir has expanded its comprehensive suite of overpressure relief products to fit a wide range of operational requirements. Intended to be used in concert with SPM® Nitrogen or Spring Relief Valves, the SPM® EXL Pressure Relief Disc is designed to provide an additional level of protection for personnel and equipment should an overpressure event occur during completion operations.

The SPM® EXL Pressure Relief Disc features a replaceable disc, which can easily be changed on site, allowing for flexibility in pressure ratings as well as lower replacement cost. This device requires minimal maintenance and provides consistent, reliable discharge within a small tolerance band of the desired rupture rating.

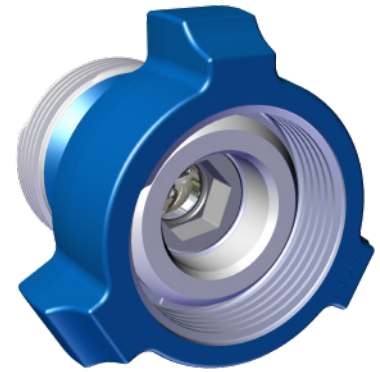

Features

- Replaceable rupture disc reduces total cost of ownership
- Replaceable discs available in wide range of set pressures
- Rupture disc machined from durable, corrosion resistant material for extended life
- Replaceable disc designed to prevent incorrect installation into the housing
- Burst test sampling on each production lot to provide performance assurance

Specifications

- Available in 2" 1502 (2A42318) and 3" 1502 (2A42229) crossover assembly housings
- Burst pressure tolerance of +/- 5% of rating¹
- Flow rate capability²:
 - 2" 1502 – 14.8 bpm (621 gpm)
 - 3" 1502 – 43 bpm (1,806 gpm)
- Sold as separate housing and disc kit assemblies:
 - Housing kit includes housing, union connection components and hex nut
 - Disc kit includes rupture disc, O-ring, and Nord-lock® washer

¹ Refer to operations manual for additional product specifications and guidance on proper usage.

² Flow rate shown for 15,000psi rated disc. Contact Weir Engineering for information regarding low rate for different pressure ratings.

Burst Pressure (psi)	2" 1502 Kit	3" 1502 Kit
2,500*	2A45144	2A44198
2,900	2A44113	N/A
6,000	2A42604	2A42600
8,350	2A43186	2A43178
9,500	2A43187	2A43179
9,800	2A43188	2A43180
10,000	2A43966	2A43965
10,500	2A42605	2A42601
11,000	2A43189	2A43181
11,500	2A43190	2A43182
12,000	2A43191	2A43183
12,500	2A42606	2A42602
13,500	2A43192	2A43184
14,500	2A42607	2A42603
14,800	2A43193	2A43185
15,000	2A42540	2A42539
15,500	2A42772	2A42781

* Minimum pressure which product could be designed to is 2,500 psi

Ball Injectors

The SPM® Sur-Drop™ Ball Injector features a “Positive Feed System,” resulting in a reliable feed and injection rate. SPM® Ball Injectors are designed to support a range of ball sizes from .88” – 1.00” and 1.13” – 1.25”. The two-piece screw assembly allows for more convenient replacement of the drive stem, without replacing the entire assembly. Adaptor kits are now available allowing users to adjust the ball size range capability by replacing the inner screw and inner housing.



Ball Injector Specifications

Size/ Pressure	Type	End Type	Temp	Service Type	Ball Size	Ball Capacity	Part Number	Weight (lb / kg)	Parts Kit
3" 1502	Manual Actuated	Male x Female	Low	Std.	1.13" – 1.25"	106	2A42011	372 / 168.7	2A28494
3" 1502	Remote Actuated – Electric	Male x Female	Low	Std.	1.13" – 1.25"	106	2A42541	480 / 217.7	2A28494
3" 1502	Manual Actuated	Male	Low	Std.	1.13" – 1.25"	106	2A42009	248 / 112.5	2A28494
3" 1502	Remote Actuated – Electric	Male	Low	Std.	1.13" – 1.25"	106	2A42542	CE*	2A28494
3" 1502	Manual Actuated	Male x Female	Low	Std.	.88" – 1.00"	129	2A29763	372 / 168.7	2A28494
3" 1502	Remote Actuated – Electric	Male x Female	Low	Std.	.88" – 1.00"	129	2A29764	480 / 217.7	2A28494
3" 1502	Manual Actuated	Male	Low	Std.	.88" – 1.00"	129	2A29757	248 / 112.5	2A28494
3" 1502	Remote Actuated – Electric	Male	Low	Std.	.88" – 1.00"	129	2A29758	CE*	2A28494

NOTE: CE*– Contact Engineering for specific details.

Screw Kit Assemblies

Ball Size Range	Part Number
1.13" – 1.25"	2P42024
.88" – 1.00"	2P42023

Kit Contents

Parts Kit: screw, seals, bearing, snap rings, pins, backup ring

Adjustable and Positive Choke Valves

SPM® Adjustable and Positive Choke Valves provide flow restriction in high pressure applications such as choke manifolds and flow through manifolds. The SPM® Choke Valve restricts the flow by reducing the flow area through the valve body to achieve a desired rate. SPM® 2" 1502 Choke Valves have a maximum orifice size of 1" while SPM® 3" 1502 Choke Valves have a maximum orifice size of 2".

SPM® Adjustable Choke Valves use a stem and seat combination to control the flow rate. The desired flow rate is adjusted by turning the hand wheel to achieve a calibrated orifice size and associated flow coefficient. The orifice size is read from an indicator which is calibrated in 1/64" increments and is lined up with a V-notch machined into the top of the bonnet.

SPM® Positive Choke Valves provide a fixed flow rate through the use of a choke bean. The flow rate is controlled by the choke bean orifice size.

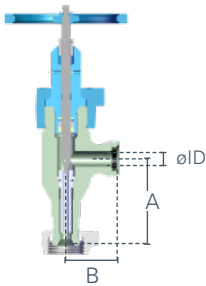

Adjustable Choke Specifications

End Type	Style	Connection Type	Temp	Service Type	Part Number	Dim. A (in / mm)	Dim. B (in / mm)	Inner Dia. (in / mm)	Weight (lb / kg)
2" 1502F x 2" 1502M	0.75 Seat	Hammer Union	Low	Std.	2A18156-0.75	9.91 / 251.7	6.06 / 153.9	1.75 / 44.5	150 / 68
2" 1502F x 2" 1502M	0.75 Seat	Hammer Union	Low	H ₂ S	2A19461-0.75	9.91 / 251.7	6.06 / 153.9	1.75 / 44.5	150 / 68
2" 1502M x 2" 1502F	0.75 Seat	Hammer Union	Low	Std.	2A18158-0.75	9.91 / 251.7	6.06 / 153.9	1.75 / 44.5	150 / 68
2" 1502F x 2" 1502F	0.75 Seat	Hammer Union	Low	Std.	2A18159-0.75	9.91 / 251.7	6.06 / 153.9	1.75 / 44.5	142 / 64.4
2" 1502F x 2" 1502M	1.00 Seat	Hammer Union	Low	Std.	2A18156-1.00	9.91 / 251.7	6.06 / 153.9	1.75 / 44.5	150 / 68
2" 1502F x 2" 1502M	1.00 Seat	Hammer Union	Low	H ₂ S	2A19461-1.00	9.91 / 251.7	6.06 / 153.9	1.75 / 44.5	150 / 68
2" 1502M x 2" 1502M	1.00 Seat	Hammer Union	Low	Std.	2A18157-1.00	9.91 / 251.7	6.06 / 153.9	1.75 / 44.5	148 / 67.1
2" 1502M x 2" 1502F	1.00 Seat	Hammer Union	Low	Std.	2A18158-1.00	9.91 / 251.7	6.06 / 153.9	1.75 / 44.5	150 / 68
3" 1502F x 3" 1502M	2.00 Seat	Hammer Union	Low	Std.	2A21253	11.88 / 301.8	8.38 / 212.9	2.50 / 63.5	205 / 93
3" 1502F x 3" 1502M	2.00 Seat	Hammer Union	Low	H ₂ S	2A23122	11.88 / 301.8	8.38 / 212.9	2.50 / 63.5	205 / 93

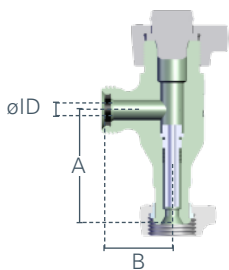

Positive Choke Specifications

End Type	Style	Connection Type	Temp	Service Type	Part Number	Dim. A (in / mm)	Dim. B (in / mm)	Inner Dia. (in / mm)	Weight (lb / kg)
2" 1502M x 2" 1502F	w/o Bean	Hammer Union	Low	Std.	2A18160	9.91 / 251.7	6.06 / 153.9	1.75 / 44.5	113 / 51.3
2" 1502M x 2" 1502F	0.75 Seat	Hammer Union	Low	Std.	2A18160-0.75	9.91 / 251.7	6.06 / 153.9	1.75 / 44.5	113 / 51.3
2" 1502M x 2" 1502F	w/o Bean	Hammer Union	Low	H ₂ S	2A22016	9.91 / 251.7	6.06 / 153.9	1.75 / 44.5	113 / 51.3

NOTE: Other parts or configurations may be available. Contact Weir for specific details.

NOTE: Listed weights are approximate.

Integrals

Weir manufactures a full line of robust, high-pressure integral union connections in a broad range of configurations and sizes from 2" through 4" and in pressure ratings to 15,000 psi NSCWP. Manufactured from high strength alloy steel forgings, SPM® Integral Union Connections are available in lateral, tee, wye, ell and cross configurations.

Laterals

NOTE: The branch configuration as described below corresponds with the branch labels in this illustration.

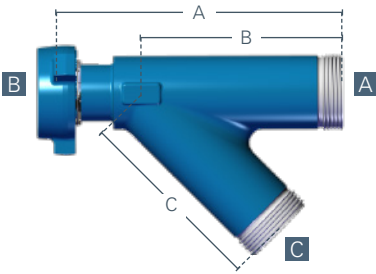

Branch Config. A	Branch Config. B	Branch Config. C	Temp	Service Type	Part Number	Dim. A (in/mm)	Dim. B (in/mm)	Dim. C (in/mm)	Inner Dia. (in / mm)	Weight (lb)
2" 1502F	2" 1502M	2" 1502F	Low	Std.	3L11611	15.75 / 400.1	9.87 / 250.7	9.87 / 250.70	1.75 / 44.5	51
2" 1502M	2" 1502F	2" 1502F	Low	Std.	3L14032	15.75 / 400.1	9.87 / 250.7	9.87 / 250.70	1.75 / 44.5	51
2" 1502M	2" 1502F	2" 1502M	Low	Std.	3A22184	15.75 / 400.1	9.87 / 250.7	9.87 / 250.70	1.75 / 44.5	60
3" 1502F	3" 1502M	3" 1502F	Low	Std.	3L11613	21.00 / 533.4	14.50 / 368.3	14.00 / 355.6	2.50 / 63.5	150
3" 1502M	3" 1502F	3" 1502F	Low	Std.	3A20010	21.00 / 533.4	14.50 / 368.3	14.00 / 355.6	2.50 / 63.5	150
3" 1502M	3" 1502F	3" 1502M	Low	Std.	3A16949	21.00 / 533.4	14.50 / 368.3	14.00 / 355.6	2.50 / 63.5	157
3" 15K SI	3" 15K SI	3" 15K SI	Low	Std.	2A27834	21.00 / 533.4	14.50 / 368.3	14.00 / 355.6	2.50 / 63.5	140
4" 1002F	4" 1002M	3" 1502F	Low	Std.	3A21270	21.00 / 533.4	14.50 / 368.3	14.00 / 355.6	3.75 x 2.50 / 95.3 x 63.5	131
4" 1002F	4" 1002M	4" 1002F	Low	Std.	3L12998	21.00 / 533.4	14.50 / 368.3	14.00 / 355.6	3.75 / 95.3	115
4" 1002M	4" 1002F	4" 1002F	Low	Std.	3L14670	21.00 / 533.4	14.50 / 368.3	14.00 / 355.6	3.75 / 95.3	115
4" 1002M	4" 1002F	4" 1002M	Low	Std.	2A26157	21.00 / 533.4	14.50 / 368.3	14.00 / 355.6	3.75 / 95.3	130
4" 1502F	4" 1502M	3" 1502F	Low	Std.	2A26756	23.75 / 603.3	15.88 / 403.4	15.88 / 403.4	3.75 x 2.50 / 95.3 x 63.5	221
4" 1502F	4" 1502M	4" 1502F	Low	Std.	2A21296	23.75 / 603.3	15.88 / 403.4	15.88 / 403.4	3.75 / 95.3	204
4" 15K SI	4" 1502F	3" 1502F	Low	Std.	2A28663	23.75 / 603.3	15.88 / 403.4	15.88 / 403.4	4.00 x 2.75 / 101.6 x 69.9	187
4" 15K SI	4" 15K SI	3" 1502F	Low	Std.	2A29848	23.75 / 603.3	15.88 / 403.4	15.88 / 403.4	4.00 x 2.75 / 101.6 x 69.9	198
4" 15K SI	4" 15K SI	3" 15K SI	Low	Std.	2A29419	23.75 / 603.3	15.88 / 403.4	15.88 / 403.4	4.00 x 3.00 / 101.6 x 76.2	194
4" 15K SI	4" 15K SI	4" 15K SI	Low	Std.	2A28635	23.75 / 603.3	15.88 / 403.4	15.88 / 403.4	4.00 / 101.6	191

Tees

NOTE: The branch configuration as described below corresponds with the branch labels in this illustration.

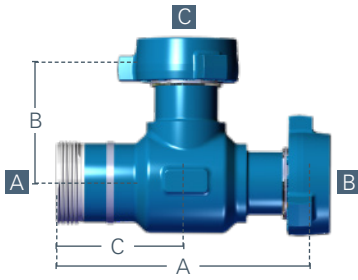

Branch Config. A	Branch Config. B	Branch Config. C	Temp	Service Type	Part Number	Dim. A (in/mm)	Dim. B (in/mm)	Dim. C (in/mm)	Inner Dia. (in / mm)	Weight (lb)
2" 1502F	2" 1502F	2" 1502F	Low	Std.	2A13794	12.13 / 308.1	6.06 / 153.9	6.06 / 153.9	1.75 / 44.5	35 / 15.9
2" 1502F	2" 1502F	2" 1502M	Low	Std.	3L13150	12.13 / 308.1	6.06 / 153.9	6.06 / 153.9	1.75 / 44.5	43 / 19.5
2" 1502F	2" 1502M	2" 1502F	Low	H ₂ S	2A16768	12.13 / 308.1	6.06 / 153.9	6.06 / 153.9	1.75 / 44.5	43 / 19.5
2" 1502F	2" 1502M	2" 1502F	Low	Std.	3L11592	12.13 / 308.1	6.06 / 153.9	6.06 / 153.9	1.75 / 44.5	44 / 20
2" 1502F	2" 1502M	2" 1502M	Low	Std.	3L13230	12.13 / 308.1	6.06 / 153.9	6.06 / 153.9	1.75 / 44.5	54 / 24.5
2" 1502F	2" 1502M	2" 1502M	Low	H ₂ S	2A16770	12.13 / 308.1	6.06 / 153.9	6.06 / 153.9	1.75 / 44.5	54 / 24.5
2" 1502M	2" 1502M	2" 1502F	Low	Std.	3L13229	12.13 / 308.1	6.06 / 153.9	6.06 / 153.9	1.75 / 44.5	53 / 24
3" 1502F	3" 1502M	2" 1502F	Low	Std.	3L11593	16.88 / 428.8	8.44 / 214.4	8.44 / 214.4	2.50 / 63.5	122 / 55.3
3" 1502F	3" 1502M	3" 1502F	Low	Std.	3L11594	16.88 / 428.8	8.44 / 214.4	8.44 / 214.4	2.50 / 63.5	120 / 54.4
3" 1502F	3" 1502M	3" 1502M	Low	Std.	3L19916	16.88 / 428.8	8.44 / 214.4	8.44 / 214.4	2.50 / 63.5	128 / 58.1
3" 1502F	3" 1502M	3" 1502M	Low	H ₂ S	3L16702	16.88 / 428.8	8.44 / 214.4	8.44 / 214.4	2.50 / 63.5	128 / 58.1
3" 1502M	3" 1502M	3" 1502M	Low	Std.	3L11599	16.88 / 428.8	8.44 / 214.4	8.44 / 214.4	2.50 / 63.5	136 / 61.7
3" 1502M	3" 1502M	2" 1502F	Low	Std.	3A24879	8.44 / 214.4	8.44 / 214.4	8.44 / 214.4	2.50 / 63.5	129 / 58.5
3" 15K SI	3" 15K SI	2" 1502F	Low	Std.	2A27997	16.75 / 425.5	8.38 / 212.9	8.44 / 214.4	2.50 / 63.5	111 / 50.3
3" 15K SI	3" 15K SI	3" 1502F	Low	Std.	2A27998	16.75 / 425.5	8.38 / 212.9	8.44 / 214.4	2.50 / 63.5	110 / 49.9
3" 15K SI	3" 15K SI	3" 15K SI	Low	Std.	2A27809	16.75 / 425.5	8.38 / 212.9	8.38 / 212.9	2.50 / 63.5	109 / 49.4
4" 1002F	4" 1002M	3" 1502F	Low	Std.	3L12827	16.88 / 428.8	8.44 / 214.4	8.44 / 214.4	3.75 / 95.3	108 / 49
4" 1002F	4" 1002M	4" 1002F	Low	Std.	3L12826	16.88 / 428.8	8.44 / 214.4	8.44 / 214.4	3.75 / 95.3	105 / 47.6
4" 1002F	4" 1002M	4" 1002M	Low	Std.	2A28544	16.88 / 428.8	8.44 / 214.4	8.44 / 214.4	3.75 / 95.3	117 / 53.1
4" 1002M	4" 1002F	2" 1502F	Low	Std.	3A19580	16.88 / 428.8	8.44 / 214.4	8.44 / 214.4	3.75 / 95.3	108 / 49
4" 1502F	4" 1502M	2" 1502F	Low	Std.	2A26065	21.00 / 533.4	10.50 / 266.7	10.50 / 266.7	3.75 / 95.3	218 / 98.9
4" 1502F	4" 1502M	3" 1502F	Low	Std.	2A25853	21.00 / 533.4	10.50 / 266.7	10.50 / 266.7	3.75 / 95.3	214 / 97.1
4" 1502F	4" 1502M	3" 15K SI	Low	Std.	2A28481	21.00 / 533.4	10.50 / 266.7	10.50 / 266.7	3.75 / 95.3	212 / 96.2
4" 1502F	4" 1502M	4" 1502F	Low	Std.	2A25990	21.00 / 533.4	10.50 / 266.7	10.50 / 266.7	3.75 / 95.3	208 / 94
4" 1502F	4" 1502M	4" 1502M	Low	Std.	2A24928	21.00 / 533.4	10.50 / 266.7	10.50 / 266.7	3.75 / 95.3	239 / 108.4
4" 1502M	4" 1502M	4" 1502F	Low	Std.	2A29970	21.00 / 533.4	10.50 / 266.7	10.50 / 266.7	3.75 / 95.3	239 / 108.4
4" 15K SI	4" 15K SI	3" 1502F	Low	Std.	2A28004	21.00 / 533.4	10.50 / 266.7	10.50 / 266.7	4.00 / 101.6	200 / 90.7
4" 15K SI	4" 15K SI	3" 1502M	Low	Std.	2A28667	21.00 / 533.4	10.50 / 266.7	10.50 / 266.7	4.00 / 101.6	202 / 91.6
4" 15K SI	4" 15K SI	3" 15K SI	Low	Std.	2A27811	21.00 / 533.4	10.50 / 266.7	10.50 / 266.7	4.00 / 101.6	197 / 89.4
4" 15K SI	4" 15K SI	4" 15K SI	Low	Std.	2A28140	21.00 / 533.4	10.50 / 266.7	10.50 / 266.7	4.00 / 101.6	198 / 89.8

NOTE: Other parts or configurations may be available. Contact Weir for specific details.

NOTE: Listed weights are approximate.

Wyes

NOTE: The branch configuration as described below corresponds with the branch labels in this illustration.

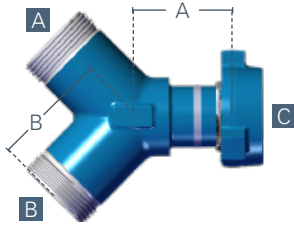

Branch Config. A	Branch Config. B	Branch Config. C	Temp	Service Type	Part Number	Dim. A (in/mm)	Dim. B (in/mm)	Inner Dia. (in / mm)	Weight (lb)
2" 1502F	2" 1502F	2" 1502M	Low	Std.	3L13139	5.25 / 133.4	5.00 / 127	1.75 / 44.5	36 / 16.3
2" 1502F	2" 1502F	2" 1502M	Low	H ₂ S	3A20226	5.25 / 133.4	5.00 / 127	1.75 / 44.5	36 / 16.3
3" 1502F	3" 1502F	3" 1502M	Low	Std.	2L14419	7.75 / 196.9	7.50 / 190.5	2.50 / 63.5	96 / 43.5
4" 1002F	4" 1002F	4" 1002M	Low	Std.	3L13141	7.75 / 196.9	7.47 / 189.7	3.75 / 95.3	82 / 37.2

NOTE: Other parts or configurations may be available. Contact Weir for specific details.

NOTE: Listed weights are approximate.

Ells

NOTE: The branch configuration as described below corresponds with the branch labels in this illustration.

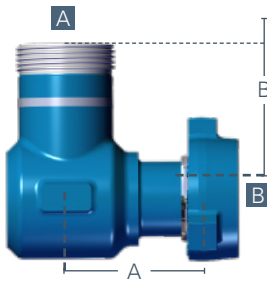

90 Degree Ells									
Branch Config. A	Branch Config. B	Temp	Service Type	Type	Part Number	Dim. A (in / mm)	Dim. B (in / mm)	Inner Dia. (in / mm)	Weight (lb / kg)
2" 1502F	2" 1502M	Low	Std.	Standard	3L13234	6.06 / 153.9	6.06 / 153.9	1.75 / 44.5	38 / 17.2
2" 1502F	2" 1502M	Low	H ₂ S	Standard	2A21068	6.06 / 153.9	6.06 / 153.9	1.75 / 44.5	38 / 17.2
2" 1502F	2" 1502M	Low	Std.	Target	2A25338	6.06 / 153.9	6.06 / 153.9	1.75 / 44.5	38 / 17.2
2" 1502F	2" 1502M	Low	H ₂ S	Target	2A25339	6.06 / 153.9	6.06 / 153.9	1.75 / 44.5	38 / 17.2
2" 1502M	2" 1502F	Low	Std.	45 Degree	3A20075	5.25 / 133.4	5.00 / 127	1.75 / 44.5	32 / 14.5
2" 1502M	2" 1502M	Low	Std.	Standard	3L14476	6.06 / 153.9	6.06 / 153.9	1.75 / 44.5	38 / 17.2
3" 1502F	3" 1502M	Low	Std.	Standard	3L14591	8.44 / 214.4	8.44 / 214.4	2.50 / 63.5	103 / 46.7
3" 1502M	3" 1502F	Low	Std.	45 Degree	1A24627	7.94 / 201.7	7.69 / 195.3	2.50 / 63.5	89 / 40.4
3" 1502M	3" 1502F	Low	Std.	Target	2A26013	8.44 / 214.4	8.44 / 214.4	2.50 / 63.5	90 / 40.8
3" 1502M	3" 1502M	Low	Std.	Standard	3L14996	8.44 / 214.4	8.44 / 214.4	2.50 / 63.5	116.4 / 52.8
3" 15K SI	2" 15K SI	Low	Std.	Standard	2A28724	8.44 / 214.4	8.38 / 212.9	1.88 / 47.8	94 / 42.6
3" 15K SI	3" 15K SI	Low	Std.	Standard	2A27838	8.38 / 212.9	8.38 / 212.9	2.50 / 63.5	97 / 44
4" 1002F	4" 1002M	Low	Std.	Standard	3L14430	8.44 / 214.4	8.44 / 214.4	3.75 / 95.3	95 / 43.1

NOTE: Other parts or configurations may be available. Contact Weir for specific details.

NOTE: Listed weights are approximate.

Ells (cont.)

NOTE: The branch configuration as described below corresponds with the branch labels in this illustration.

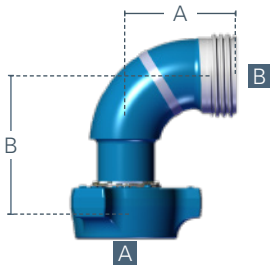

Long Radius Ells								
Branch Config. A	Branch Config. B	Temp	Service Type	Part Number	Dim. A (in / mm)	Dim. B (in / mm)	Inner Dia. (in / mm)	Weight (lb / kg)
2" 1502F	2" 1502M	Low	Std.	3A20534	5.50 / 139.7	7.16 / 181.9	1.83 / 46.5	32 / 14.5
2" 1502F	2" 1502M	Low	H ₂ S	3A20535	5.50 / 139.7	7.16 / 181.9	1.83 / 46.5	32 / 14.5
3" 1502F	3" 1502M	Low	Std.	2A34148	7.94 / 201.7	10 / 254	2.75 / 69.9	53.6 / 24.3

NOTE: Other parts or configurations may be available. Contact Weir for specific details.

NOTE: Listed weights are approximate.

Crosses

NOTE: The branch configuration as described below corresponds with the branch labels in this illustration.

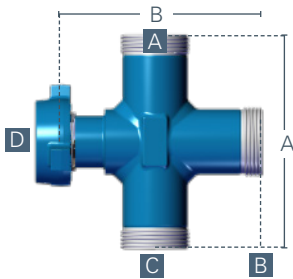

Branch Config. A	Branch Config. B	Branch Config. C	Branch Config. D	Temp	Service Type	Part Number	Dim. A (in / mm)	Dim. B (in / mm)	Inner Dia. (in / mm)	Weight (lb / kg)
2" 1502F	2" 1502F	2" 1502M	2" 1502F	Low	Std.	3L11607	12.13 / 308.1	12.13 / 308.1	1.75 / 44.5	50 / 22.7
2" 1502F	2" 1502M	2" 1502M	2" 1502M	Low	Std.	1A19904	12.13 / 308.1	12.13 / 308.1	1.75 / 44.5	68 / 30.8
3" 1502F	3" 1502F	3" 1502M	3" 1502F	Low	Std.	3L11608	16.88 / 428.8	16.88 / 428.8	2.50 / 63.5	139 / 63
3" 15K SI	3" 15K SI	3" 15K SI	2" 1502F	Low	Std.	2A29497	16.75 / 425.5	16.81 / 427	2.50 x 1.75 /	128 / 58.1
4" 1002F	4" 1002F	4" 1002M	4" 1002F	Low	Std.	3A22179	16.88 / 428.8	16.88 / 428.8	63.5 x 44.5	128 / 58.1
4" 1002F	4" 1002F	4" 1002M	4" 1002F	Low	Std.	3L12838	18.00 / 457.2	16.88 / 428.8	3.75 / 95.3	114 / 51.7

NOTE: Other parts or configurations may be available. Contact Weir for specific details.

NOTE: Listed weights are approximate.

SPM® Pipe

Weir offers pipe in both non-pressure seal (NPS) and integral styles. Sizes available may vary by style but Weir provides pipe in many lengths up to 180". Contact Weir for specific non-standard lengths.

NPS Pipe

Weir offers NPS pipe in sizes 2" 1502, 3" 1502, 4" 1002 and 4" 1502 configurations. In applications involving strong cyclic loading, though, Weir recommends the use of integral pipe. SPM® NPS Pipe includes an identification groove on all non-pressure seal threaded (NPS) subs per API RP-7HU1.

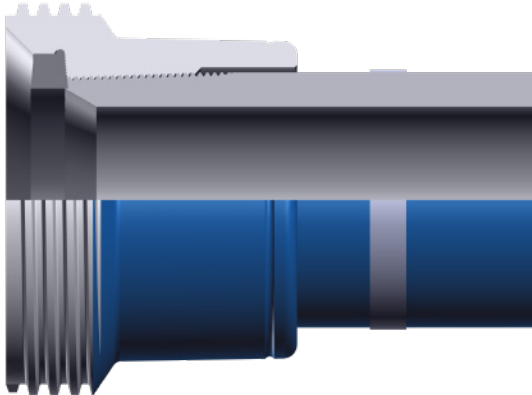

Features

- Elastomer seal protects the threads from exposure to the high pressure fluid, allowing for greater working pressure ratings
- Threaded sub incorporates epoxy for a permanent assembly bond
- Threaded tubing is flush with the seal pocket

Tolerances

- Tolerance of the face to face length of SPM® NPS Pipe:
 - 2" 1502: +/- .72"
 - 3" 1502: +/- .72"
 - 4" 1002: +/- .72"
 - 4" 1502: +/- .72"

2" 1502 NPS Pipe

Style	Length	Connection Type	Temp	Service Type	Part Number	Inner Dia. (in / mm)	Weight (lb / kg)
Non-Detachable	24"	Hammer Union	Low	Std.	2A12519	1.75 / 44.5	31 / 14.1
Non-Detachable	36"	Hammer Union	Low	Std.	2A12521	1.75 / 44.5	38 / 17.2
Non-Detachable	48"	Hammer Union	Low	Std.	2A12525	1.75 / 44.5	45 / 20.4
Non-Detachable	60"	Hammer Union	Low	Std.	2A12526	1.75 / 44.5	52 / 23.6
Non-Detachable	72"	Hammer Union	Low	Std.	2A12527	1.75 / 44.5	59 / 26.8
Non-Detachable	96"	Hammer Union	Low	Std.	2A12528	1.75 / 44.5	72 / 32.7
Non-Detachable	120"	Hammer Union	Low	Std.	2A12530	1.75 / 44.5	86 / 39
Detachable - Shoulder	24"	Hammer Union	Low	Std.	2A22811	1.75 / 44.5	31 / 14.1
Detachable - Shoulder	36"	Hammer Union	Low	Std.	2A22766	1.75 / 44.5	38 / 17.2
Detachable - Shoulder	48"	Hammer Union	Low	Std.	2A22812	1.75 / 44.5	45 / 20.4
Detachable - Shoulder	60"	Hammer Union	Low	Std.	2A22813	1.75 / 44.5	52 / 23.6
Detachable - Shoulder	72"	Hammer Union	Low	Std.	2A22814	1.75 / 44.5	59 / 26.8
Detachable - Shoulder	96"	Hammer Union	Low	Std.	2A22815	1.75 / 44.5	73 / 33.1
Detachable - Shoulder	120"	Hammer Union	Low	Std.	2A22816	1.75 / 44.5	86 / 39

NOTE: Other parts or configurations may be available. Contact Weir for specific details.

NOTE: Listed weights are approximate.

NPS Pipe (cont.)

3" 1502 NPS Pipe							
Style	Length	Connection Type	Temp	Service Type	Part Number	Inner Dia. (in / mm)	Weight (lb / kg)
Non-Detachable	24"	Hammer Union	Low	Std.	2A12554	2.56 / 65	57 / 25.9
Non-Detachable	36"	Hammer Union	Low	Std.	2A12556	2.56 / 65	72 / 32.7
Non-Detachable	48"	Hammer Union	Low	Std.	2A12559	2.56 / 65	87 / 39.5
Non-Detachable	60"	Hammer Union	Low	Std.	2A12562	2.56 / 65	103 / 46.7
Non-Detachable	72"	Hammer Union	Low	Std.	2A12563	2.56 / 65	118 / 53.5
Non-Detachable	96"	Hammer Union	Low	Std.	2A12565	2.56 / 65	148 / 67.1
Non-Detachable	120"	Hammer Union	Low	Std.	2A12568	2.56 / 65	178 / 80.7
Detachable - Shoulder	24"	Hammer Union	Low	Std.	2A22820	2.56 / 65	57 / 25.9
Detachable - Shoulder	36"	Hammer Union	Low	Std.	2A22768	2.56 / 65	72 / 32.7
Detachable - Shoulder	48"	Hammer Union	Low	Std.	2A22821	2.56 / 65	87 / 39.5
Detachable - Shoulder	60"	Hammer Union	Low	Std.	2A22822	2.56 / 65	102 / 46.3
Detachable - Shoulder	72"	Hammer Union	Low	Std.	2A22823	2.56 / 65	118 / 53.5
Detachable - Shoulder	96"	Hammer Union	Low	Std.	2A22824	2.56 / 65	148 / 67.1
Detachable - Shoulder	120"	Hammer Union	Low	Std.	2A22825	2.56 / 65	178 / 80.7

NOTE: Other parts or configurations may be available.
Contact Weir for specific details.

NOTE: Listed weights are approximate.

4" 1002 NPS Pipe							
Style	Length	Connection Type	Temp	Service Type	Part Number	Inner Dia. (in / mm)	Weight (lb / kg)
Non-Detachable	24"	Hammer Union	Low	Std.	2A28239	3.65 / 92.7	63 / 28.6
Non-Detachable	36"	Hammer Union	Low	Std.	2A28240	3.65 / 92.7	82 / 37.2
Non-Detachable	48"	Hammer Union	Low	Std.	2A28243	3.65 / 92.7	100 / 43.4
Non-Detachable	60"	Hammer Union	Low	Std.	2A28245	3.65 / 92.7	119 / 54
Non-Detachable	72"	Hammer Union	Low	Std.	2A28246	3.65 / 92.7	137 / 62.1
Non-Detachable	96"	Hammer Union	Low	Std.	2A28251	3.65 / 92.7	174 / 78.9
Non-Detachable	120"	Hammer Union	Low	Std.	2A28254	3.65 / 92.7	211 / 95.7
Detachable - Shoulder	24"	Hammer Union	Low	Std.	2A28881	3.65 / 92.7	67 / 30.4
Detachable - Shoulder	36"	Hammer Union	Low	Std.	2A28882	3.65 / 92.7	85 / 38.6
Detachable - Shoulder	48"	Hammer Union	Low	Std.	2A28883	3.65 / 92.7	104 / 47.2
Detachable - Shoulder	72"	Hammer Union	Low	Std.	2A28886	3.65 / 92.7	140 / 63.5
Detachable - Shoulder	96"	Hammer Union	Low	Std.	2A28887	3.65 / 92.7	177 / 80.3
Detachable - Shoulder	120"	Hammer Union	Low	Std.	2A28888	3.65 / 92.7	214 / 97.1

NOTE: Other parts or configurations may be available.
Contact Weir for specific details.

NOTE: Listed weights are approximate.

4-1502 NPS Pipe							
Style	Length	Connection Type	Temp	Service Type	Part Number	Inner Dia. (in / mm)	Weight (lb / kg)
Non-Detachable	24"	Hammer Union	Low	Std.	2A24473	3.75 / 95.3	56 / 25.4
Non-Detachable	36"	Hammer Union	Low	Std.	2A24474	3.75 / 95.3	85 / 38.6
Non-Detachable	48"	Hammer Union	Low	Std.	2A24475	3.75 / 95.3	172 / 78.0
Non-Detachable	60"	Hammer Union	Low	Std.	2A24476	3.75 / 95.3	202 / 91.6
Non-Detachable	72"	Hammer Union	Low	Std.	2A24477	3.75 / 95.3	173 / 78.5
Non-Detachable	96"	Hammer Union	Low	Std.	2A24478	3.75 / 95.3	289 / 131.1
Non-Detachable	120"	Hammer Union	Low	Std.	2A24479	3.75 / 95.3	348 / 157.9

Integral Pipe and Crossovers

Weir offers robust integral pipe in sizes 2" through 4" in pressure ratings to 15,000 psi NSCWP. SPM® Integral Pipe is recommended for use in applications where strong cyclic loading is possible. SPM® Integral Pipe is available in standard length pup joints in 2" and 3" 1502 configurations, or custom length long-crossovers in 2" through 4" 1502 and 4" 1002 configurations.

Features

- Single piece of forged metal with machined hammer union or SPM® Safety Iron® connections (no subs)
- Forged surface on O.D.
- Available in standard lengths only

Tolerances

- Tolerance of the face to face length of SPM® Integral Pup Joints:
 - 2" 1502: +/- .25"
 - 3" 1502: +/- .25"

Pup Joints

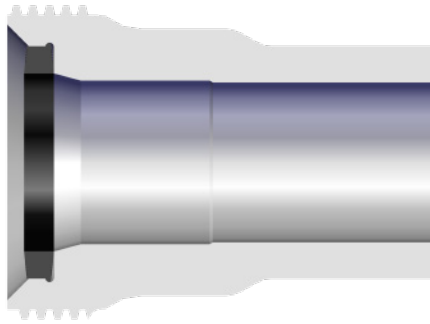

2" 1502 Pup Joints

Length	Connection Type	Temp	Service Type	Part Number	Inner Dia. (in / mm)	Weight (lb / kg)
24"	Hammer Union	Low	Standard	2A38920	1.75 / 44.5	34 / 15.4
36"	Hammer Union	Low	Standard	2A38921	1.75 / 44.5	42 / 19.1
48"	Hammer Union	Low	Standard	2A19448	1.75 / 44.5	50 / 22.7
48"	Hammer Union	Low	H ₂ S	2A19453	1.75 / 44.5	50 / 22.7
60"	Hammer Union	Low	Standard	2A20387	1.75 / 44.5	60 / 27.2
60"	Hammer Union	Low	H ₂ S	2A22081	1.75 / 44.5	60 / 27.2
72"	Hammer Union	Low	Standard	2A19859	1.75 / 44.5	71 / 32.2
72"	Hammer Union	Low	H ₂ S	2A19856	1.75 / 44.5	71 / 32.2
90"	Hammer Union	Low	Standard	2A19449	1.75 / 44.5	80 / 36.3
90"	Hammer Union	Low	H ₂ S	2A19454	1.75 / 44.5	80 / 36.3
114"	Hammer Union	Low	Standard	2A19861	1.75 / 44.5	98 / 44.5
114"	Hammer Union	Low	H ₂ S	2A19858	1.75 / 44.5	98 / 44.5

NOTE: Other parts or configurations may be available. Contact Weir for specific details.

Pup Joints (cont.)

3" 1502 Pup Joints							
Length	Connection Type	End Configuration	Temp	Service Type	Part Number	Inner Dia. (in / mm)	Weight (lb / kg)
24"	Hammer Union		Low	Standard	2A38935	2.75 / 69.8	69 / 31.3
36"	Hammer Union		Low	Standard	2A38936	2.75 / 69.8	91 / 41.3
48"	Hammer Union		Low	Standard	2A20522	2.75 / 69.8	113 / 51.3
48"	Mix	3" 15K SI x 3" 1502F	Low	Standard	2A28216	2.75 / 69.8	100 / 43.4
48"	Mix	3" 15K SI x 3" 1502M	Low	Standard	2A28179	2.75 / 69.8	97 / 44
48"	SPM® Safety Iron®		Low	Standard	2A27906	2.75 / 69.8	100 / 43.4
48"	Hammer Union		Low	H ₂ S	2A20527	2.75 / 69.8	113 / 51.3
60"	Hammer Union		Low	Standard	2A24677	2.75 / 69.8	136 / 61.7
60"	SPM® Safety Iron®		Low	Standard	2A27907	2.75 / 69.8	123 / 55.8
60"	Hammer Union		Low	H ₂ S	2A22596	2.75 / 69.8	136 / 61.7
72"	Hammer Union		Low	Standard	2A20523	2.75 / 69.8	158 / 71.7
72"	Hammer Union		Low	H ₂ S	2A20528	2.75 / 69.8	158 / 71.7
90"	Hammer Union		Low	Standard	2A20524	2.75 / 69.8	191 / 86.6
90"	SPM® Safety Iron®		Low	Standard	2A27909	2.75 / 69.8	179 / 81.2
96"	Hammer Union		Low	Standard	2A20525	2.75 / 69.8	202 / 91.6
114"	Hammer Union		Low	Standard	2A20526	2.75 / 69.8	237 / 107.5
114"	Hammer Union		Low	H ₂ S	2A20531	2.75 / 69.8	237 / 107.5
120"	Hammer Union		Low	Standard	2A40952	2.75 / 69.8	250 / 113.4

NOTE: Other parts or configurations may be available. Contact Weir for specific details.

Integral Crossovers

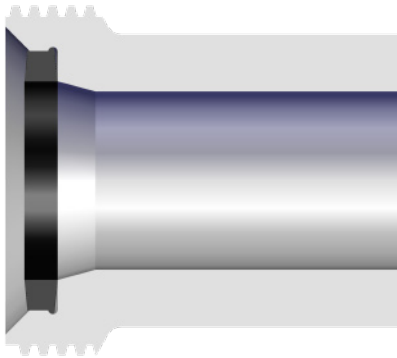

Features

- Single piece of forged metal with machined hammer union or SPM® Safety Iron® connections (no subs)
- Machined surface on O.D.
- Custom lengths available

Tolerances

- Tolerance of the face to face length of integral crossovers:
 - 2" 1502 <24" length: +/- .03"
 - 2" 1502 >24" length: +/- .06"
 - 3" 1502 <24" length: +/- .03"
 - 3" 1502 >24" length: +/- .06"
 - 4" 1002 <24" length: +/- .03"
 - 4" 1002 >24" length: +/- .06"
 - 4" 1502 <24" length: +/- .03"
 - 4" 1502 >24" length: +/- .06"

Integral Crossovers (cont.)

Short Crossovers (under 24")						
Outlet / Branch Configuration	Length	Temp	Service Type	Part Number	Inner Dia. (in / mm)	Weight (lb / kg)
2" 1502F x 2" 1502F	7"	Low	Standard	2P10026	1.75 / 44.5	16 / 7.3
2" 1502M x 2" 1502F	7"	Low	Standard	3A22139	1.75 / 44.5	22 / 10
2" 1502M x 2" 1502M	7"	Low	Standard	3L11571	1.75 / 44.5	32 / 14.5
2" 1502M x 3" 1502F	7"	Low	Standard	3A20090	1.75 / 44.5	30 / 13.6
2" 1502M x 3" 1502M	7"	Low	Standard	3A20088	1.75 / 44.5	42 / 19.1
3" 1502M x 2" 1502F	5.62"	Low	Standard	3A20089	1.75 / 44.5	32 / 14.5
3" 1502M x 3" 1502M	7"	Low	Standard	3A20576	2.50 / 63.5	50 / 22.7
3" 1502M x 4" 1502F	7"	Low	Standard	2A28957	2.50 / 63.5	40 / 18.1
3" 1502F x 3" 1502F	7"	Low	Standard	3P19728	2.75 / 69.9	25.2 / 11.4
3" 1502F x 3" 1502M	7"	Low	Standard	3A24049	2.75 / 69.9	33.1 / 15
3" 1502F x 3" 1502M	12"	Low	Standard	2A29009	2.75 / 69.9	47.7 / 21.6
3" 1502F x 4" 1002M	7"	Low	Standard	3A27276LT	2.75 / 69.9	44.4 / 20.3
3" 1502F x 4" 1502M	7"	Low	Standard	2A28918	2.50 / 127	73.5 / 33.3
4" 1002F x 3" 1502M	7"	Low	Standard	3L27278LT	2.75 / 69.9	36.1 / 16.4
4" 1002M x 4" 1002M	7"	Low	Standard	3A27274LT	3.75 / 95.3	57.7 / 26.2
3" 15K SI x 2" 1502F	5"	Low	Standard	2A27785	1.75 / 44.5	15 / 6.8
3" 15K SI x 2" 1502M	6"	Low	Standard	2A27788	1.75 / 44.5	25 / 11.3
3" 15K SI x 3" 1502F	5"	Low	Standard	2A27901LT	2.50 / 63.5	17 / 7.7
3" 15K SI x 3" 1502M	6"	Low	Standard	2A27903LT	2.50 / 63.5	32 / 14.5
3" 15K SI x 4" 10K SI	5"	Low	Standard	2A27792	3.00 / 76.2	19 / 8.6
4" 10K SI x 2" 1502F	6"	Low	Standard	2A28158	1.75 / 44.5	39 / 17.7
4" 10K SI x 2" 1502M	7"	Low	Standard	2A27791	1.75 / 44.5	32 / 14.5
4" 10K SI x 3" 1502F	5"	Low	Standard	2A27786	2.50 / 63.5	21 / 9.5
4" 10K SI x 4" 1002M	7.25"	Low	Standard	2A27980LT	5.00 / 127	42 / 19.1
4" 10K SI x 3" 15K SI	5"	Low	Standard	2A26294	3.00 / 76.2	19 / 8.6
4" 1502F x 4" 1502F	7"	Low	Standard	2A33139	3.75 / 95.3	36 / 16.3
4" 1502M x 4" 1502F	7.5"	Low	Standard	2A28702	3.75 / 95.3	69 / 31.3
4" 15K SI x 2" 1502F	6"	Low	Standard	2A28158	1.75 / 44.5	39 / 17.7
4" 15K SI x 3" 1502F	6"	Low	Standard	2A28156	4.00 / 101.6	39 / 17.7
4" 15K SI x 3" 1502M	8.5"	Low	Standard	2A28136	2.50 / 63.5	59 / 26.8
4" 15K SI x 3" 15K SI	7"	Low	Standard	2A27789	3.00 / 76.2	42 / 19.1
4" 15K SI x 4" 1002F	6"	Low	Standard	2A28157	4.00 / 101.6	37 / 16.8
4" 15K SI x 4" 1002M	9.25"	Low	Standard	2A28159	3.75 / 95.3	64 / 29
4" 15K SI x 4" 10K SI	7"	Low	Standard	2A29687	4.00 / 101.6	40 / 18.1
4" 15K SI x 4" 1502F	6"	Low	Standard	2A28138	4.00 / 101.6	39 / 17.7
4" 15K SI x 4" 1502M	8.5"	Low	Standard	2A28139	3.75 / 95.3	85 / 38.6
4" 15K SI x 4" 15K SI	12"	Low	Standard	2A28330	4.00 / 101.6	80 / 36.3
2" 1502F x 2" 1502F	7"	Low	H ₂ S	3P18499	1.75 / 44.5	16 / 7.3
2" 1502F x 3" 1502F	7"	Low	H ₂ S	3P19736	1.75 / 44.5	27 / 12.2
2" 1502M x 2" 1502F	5"	Low	H ₂ S	2A26273	1.75 / 44.5	19 / 8.6
2" 1502M x 2" 1502F	7"	Low	H ₂ S	3A19476	1.75 / 44.5	22 / 10
2" 1502M x 2" 1502F	12"	Low	H ₂ S	3A20962	1.75 / 44.5	31 / 14.1
2" 1502M x 2" 1502M	7"	Low	H ₂ S	3A18501	1.75 / 44.5	31 / 14.1
2" 1502M x 3" 1502F	7"	Low	H ₂ S	3A20095	1.75 / 44.5	29 / 13.2
2" 1502M x 3" 1502M	7"	Low	H ₂ S	3A20092	1.75 / 44.5	43 / 19.5
3" 1502F x 3" 1502F	7"	Low	H ₂ S	3P19741	2.50 / 63.5	27 / 12.2
3" 1502M x 2" 1502F	5.62"	Low	H ₂ S	3A20093	1.75 / 44.5	32 / 14.5
3" 1502M x 3" 1502F	7"	Low	H ₂ S	3A21058	2.75 / 69.8	34 / 15.4
3" 1502M x 3" 1502M	7"	Low	H ₂ S	3A20091	2.50 / 63.5	50 / 22.7

NOTE: Other parts or configurations may be available. Contact Weir for specific details.

NOTE: Listed weights are approximate.

Integral Crossovers (cont.)

Long Crossovers (over 24")						
Outlet / Branch Configuration	Length	Temp	Service Type	Part Number	Inner Dia. (in / mm)	Weight (lb / kg)
2" 1502M x 2" 1502F	24"	Low	Standard	3A23824	1.75 / 44.5	51 / 23.1
2" 1502M x 2" 1502F	36"	Low	Standard	3A23376	1.75 / 44.5	71 / 32.2
3" 1502F x 3" 1502F	36"	Low	Standard	2A29618	2.50 / 63.5	149 / 67.6
3" 1502M x 3" 1502F	24"	Low	Standard	2A29010	2.75 / 69.8	82 / 37.2
3" 1502M x 3" 1502F	36"	Low	Standard	2A29011	2.75 / 69.8	116 / 52.6
3" 1502M x 3" 1502F	48"	Low	Standard	2A34098	2.75 / 69.8	149 / 67.6
3" 15K SI x 3" 15K SI	24"	Low	Standard	2A33092	2.50 / 63.5	72 / 32.7
4" 1002F x 4" 1002M	60"	Low	Standard	2A29767	3.75 / 95.3	169.5 / 76.9
4" 1002F x 4" 1002M	120"	Low	Standard	2A36885	3.75 / 95.3	379.5 / 172.1
4" 1002F x 4" 1002M	24"	Low	Standard	2A34112	3.75 / 95.3	90.9 / 41.2
4" 1002F x 4" 1002M	36"	Low	Standard	2A34114	3.75 / 95.3	127.0 / 57.6
4" 1002F x 4" 1002M	48"	Low	Standard	2A34116	3.75 / 95.3	163.1 / 74.0
4" 1002F x 4" 1002M	96"	Low	Standard	2A34118	3.75 / 95.3	307.4 / 139.4
4" 1502M x 4" 1502F	24"	Low	Standard	2A28375	3.75 / 95.3	123 / 55.8
4" 1502M x 4" 1502F	36"	Low	Standard	2A28704	3.75 / 95.3	163 / 73.9
4" 1502M x 4" 1502F	48"	Low	Standard	2A28705	3.75 / 95.3	203 / 92.1
4" 1502M x 4" 1502F	60"	Low	Standard	2A28709	3.75 / 95.3	242 / 109.8
4" 1502M x 4" 1502F	72"	Low	Standard	2A28630	3.75 / 95.3	282 / 127.9
4" 1502M x 4" 1502F	96"	Low	Standard	2A29028	3.75 / 95.3	361 / 163.7
4" 1502M x 4" 1502F	120"	Low	Standard	2A28706	3.75 / 95.3	441 / 200
4" 1502M x 4" 1502F	144"	Low	Standard	2A28969	3.75 / 95.3	520 / 235.9
4" 15K SI x 4" 15K SI	24"	Low	Standard	2A28167	4.00 / 101.6	141 / 64
4" 15K SI x 4" 15K SI	48"	Low	Standard	2A28831	4.00 / 101.6	265 / 120.2
4" 15K SI x 4" 15K SI	60"	Low	Standard	2A28873	4.00 / 101.6	327 / 148.3
4" 15K SI x 4" 15K SI	72"	Low	Standard	2A28689	4.00 / 101.6	388 / 176
4" 15K SI x 4" 15K SI	84"	Low	Standard	2A28961	4.00 / 101.6	450 / 204.1
4" 15K SI x 4" 15K SI	96"	Low	Standard	2A28900	4.00 / 101.6	512 / 232.2

NOTE: Other parts or configurations may be available.
Contact Weir for specific details.

NOTE: Listed weights are approximate.

SPM® Hose Loops

SPM® All-Steel Hoses utilize field-proven SPM® Swivel joints for greater flexibility, shock and vibration resistance, and uniform flow. SPM® Hoses are designed to easily and conveniently fold up for storage and transportation

2" 1502 Hose Loops							
Length	Style	Connection Type	Temp	Service Type	Part Number	Inner Dia. (in / mm)	Weight (lb / kg)
8'7"	C&C	Hammer Union	Low	Standard	2A17581	1.69 / 42.9	142 / 64.4
9'6"	C&C	Hammer Union	Low	Standard	2A17229	1.69 / 42.9	158 / 71.7
9'6"	C&C	Hammer Union	Low	H ₂ S	2A17230	1.69 / 42.9	158 / 71.7



NOTE: Other parts or configurations may be available.
Contact Weir for specific details.

NOTE: Listed weights are approximate.

SPM® Hammer Unions

SPM® Hammer Unions provide pressure-tight, positive sealing and are available for standard service and sour gas service. Hammer unions feature easy identification of size and pressure rating.

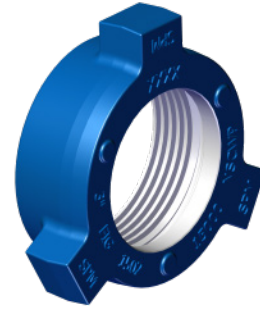

Hammer Unions				
Figure Number	Service Type	Nominal Pipe Size (inches / mm)		
		2 / 50.8	3 / 76.2	4 / 101.6
200	Standard	3P12004	2P12009	2P11765
206	Standard	3P12004	2P12009	2P11765
1002	Standard			Detachable – 2P10963 NonDetachable – 2P10965
1502	Standard – EXL		2P41604	
1502	Standard	3P10228		2P11729
1502	H ₂ S	2P13710	2P14370	
2002	Standard	2P14202	2P19422	
2202	H ₂ S	2P14714	2P19342	

NOTE: Other parts or configurations may be available. Contact Weir for specific details.

Union Assemblies					
Figure Number	Service Type	Connection Type	Nominal Pipe Size (inches / mm)		
			2 / 50.8	3 / 76.2	4 / 101.6
200	Standard	Pressure Seal	3A12006		2A11831
206	Standard	Buttweld SCH 40		2A12024	2A12029
206	Standard	Pressure Seal	3A12008	2A12014	2A11637
1002	Standard	Pressure Seal			2A10964
1502	Standard	Buttweld SCH XXH	Detachable - 2A10224 NonDetach. - 2A12265	2A12267	
1502	Standard	Pressure Seal	2A10223	2A10252	
1502	H ₂ S	Buttweld SCH XXH	Detachable - 2A14925	2A14621	

NOTE: Other parts or configurations may be available. Contact Weir for specific details.

Warning

UNION INTERCHANGEABILITY – Each union connection is clearly marked with a pressure code (e.g. “1502”). This pressure must not be exceeded. This code should also be used with mating unions. Improper mating can result in failures, and lead to **SERIOUS BODILY INJURY, DEATH, OR PROPERTY DAMAGE**. All mating integral union connections must match (according to size, pressure rating, etc). These connections must also match the service of the designated string they are installed in.

REPLACEMENT OF COMPONENT PARTS – It is critical that SPM® Hammer Union component parts, particularly retainer segments and rings, be replaced only with SPM® parts of the same size and pressure rating. Do not mix retainer segments and rings from other manufacturers within SPM® Hammer Union connections.

SPM® EXL Wing Nuts

Design Challenges

There are two primary sources of wingnut failure: fatigue cracks from cyclical loading and excessive load impact from hammer strikes. Continual side load forces paired with the typical pulsations produced during pumping operations create significant levels of stress on hammer unions. Consequently, fatigue crack formations may develop at the thread root which can propagate axially and lead to an unexpected separation.

The Solution

The patented SPM® EXL Wing Nut helps address failures at their source and features a full root radius on the internal threads to help minimize stress concentrations. This design feature also provides the additional benefit of added clearance for debris accumulation in the threads, assisting with proper assembly. Thicker lugs that extend forward, paired with a larger outside diameter, reduce cracking by suppressing the propagation path and provide a greater surface area to absorb hammer impact loads.

The SPM® EXL Wing Nut can be retrofitted to existing SPM® product and is compatible with most existing hammer union connections of comparable size and pressure rating.

Design Validation

The SPM® EXL Wing Nut is engineered to minimize stress concentrations at critical locations. A comprehensive analysis confirmed the design reduced fatigue stress resulting in a 235% increase in cycles prior to failure. This fatigue analysis is based on 1,500 lb. alternating side load.

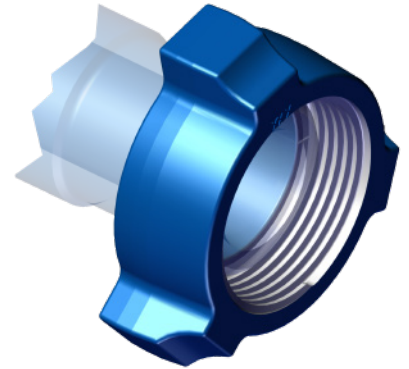

US PATENT 10,557,576

Features

- Complies with pending API 7HU2 requirements
- Compatible make-up with most existing hammer union connections of like size and pressure rating
- Retrofittable onto SPM® products of like size and pressure rating

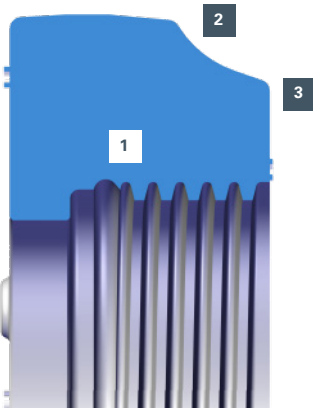

- 1** Full root radius on internal threads to help minimize stress
- 2** Extended, forward-facing lugs to reduce cracking
- 3** Thicker lugs and larger outside diameter to extend life

SPM® EXL Wing Nut

Size	Part Number
2" 1502	2P42139
3" 1502	2P41604
4" 1002	2P42167
4" 1502	2P42147

SPM® Bull Plugs and Gauge Plugs

Bull Plugs				
Configuration	Temp	Service Type	Part Number	Weight (lb / kg)
2" 1502M	Low	Standard	3A20349	15.8 / 7.2
2" 1502F	Low	Standard	3P18786	6.6 / 3.0
3" 1502M	Low	Standard	3A20681	15.8 / 7.2
3" 1502F	Low	Standard	3P21148	12.5 / 5.7
4" 1502M	Low	Standard	2A33142	63.5 / 28.8

NOTE: Other parts or configurations may be available. Contact Weir for specific details.

NOTE: Listed weights are approximate.



Gauge Plugs					
Configuration	Temp	Service Type	Type	Part Number	Weight (lb / kg)
2" 1502M	Low	Standard	.50 NPT	3A21291	15.7 / 7.1
2" 1502F	Low	Standard	.50 NPT	3P18897	6.3 / 2.8
3" 1502M	Low	Standard	.50 NPT	3A21316	27.6 / 12.5
3" 1502F	Low	Standard	.50 NPT	3P21318	12.4 / 5.6
4" 1002M	Low	Standard	.50 NPT	2A39820	33.9 / 15.4
4" 1002F	Low	Standard	.50 NPT	3P10996	17.3 / 7.8

NOTE: Other parts or configurations may be available. Contact Weir for specific details.

NOTE: Listed weights are approximate.

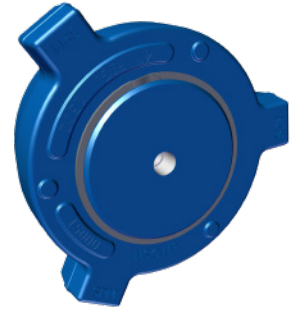

SPM® Safety Iron®

SPM® Safety Iron® is a clamp connecting flow line system developed to provide a more robust connection than the traditional hammer union connections. The product consists of a seal ring utilizing a soft seal and a metal-to-metal seal, an upper clamp with “captive” bolts, and a lower threaded clamp. The metal seal ring and rubber seals freely slip into the tapered flange end. Sealing is accomplished by the end crush on the rubber seal and tapered metal contact from the clamp force. The result is a superior performing connection that is designed for flow line applications with greater load stresses.

Assembly Specifications

Weir recommends the use of a pneumatic impact wrench for primary assembly of all SPM® Safety Iron® connections. This wrench must be chosen to suit the torque requirements listed below and should have a minimum drive of 1/2". However, a 3/4" drive impact wrench is recommended for the larger SPM® 4" 15K Safety Iron® connection. If required, an adaptor can be incorporated to allow the use of larger size impact sockets.

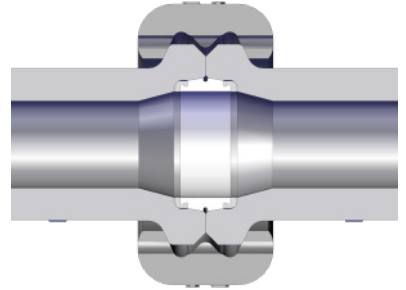

US PATENT 7,204,525

Features

- Greater vibration fatigue resistance compared to traditional hammer union alternatives.
- Large sweeping radii in high pressure components for increased strength at connections.
- Robust wall thickness to reduce the risk of failure in high risk areas.

SPM® Safety Iron® Connection Torque Values

Size	Pressure Rating (psi)	Torque (ft-lbs)
2"	15K	180 +/- 50 ft lbs
3"	15K	350 +/- 50 ft lbs
4"	10K	350 +/- 50 ft lbs
4"	15K	700 +/- 50 ft lbs

Weir recommends the use of a manual adjustable torque wrench to verify the proper torque has been applied. Also, while the iron is unpressurized, a visual inspection of the flow line should be performed to verify that all bolts are properly tightened. This can be achieved by performing a quick inspection of the line by feeling the underside of each clamp to verify the bolt is within 1/4" of the opening in the bottom threaded clamp.

SPM® Safety Iron® 3" 15K End Connection

Type	Style	Temp	Part Number	Weight (lb / kg)
Clamp Assembly		Low	2A25917	16 / 7.3
Seal Kit	Buna	Low	2A39290	0.8 / 0.36
Seal Kit	Fluoroelastomer	Low	2A39291	0.8 / 0.36

SPM® Safety Iron® 4" 15K End Connection

Type	Style	Temp	Part Number	Weight (lb / kg)
Clamp Assembly		Low	2A25402	65 / 29.5
Seal Kit	Buna	Low	2A39298	2.9 / 1.3
Seal Kit	Fluoroelastomer	Low	2A39296	2.9 / 1.3

Kit Contents

Clamp Assembly: clamp halves, bolts, retainer rings

Seal Kit: hard seal ring, soft seals

NOTE: Other parts or configurations may be available. Contact Weir for specific details.

NOTE: Listed weights are approximate.

SPM® Manifold Trailers

The SPM® Manifold Trailer provides the market with the uniquely designed SPM® Safety Iron® manifold system that is suited for stimulation operations, where vibrations and fatigue have proven to be detrimental to the existing hammer union trailer models currently on the market.

SPM® Safety Iron® connections provide a robust wall thickness with significantly increased fatigue resistance compared to traditional hammer union connections. These durable connections are superior for applications involving strong vibration and fatigue induced failures. Once properly assembled, SPM® Safety Iron® connections provide a connection that is less susceptible to leaking during operation. This means less down time and more efficient operation for its users.

Benefits of SPM® Safety Iron® connections over Hammer Unions in manifold trailer applications:

- SPM® Safety Iron® connections feature a greater I.D. than like-sized traditional hammer union iron, resulting in greater flow rate potential and reduced velocity at equivalent rates, resulting in longer lasting iron.
- SPM® Safety Iron® connections have a more robust design at critical areas of the connections versus hammer unions:



Traditional Hammer Union Connection

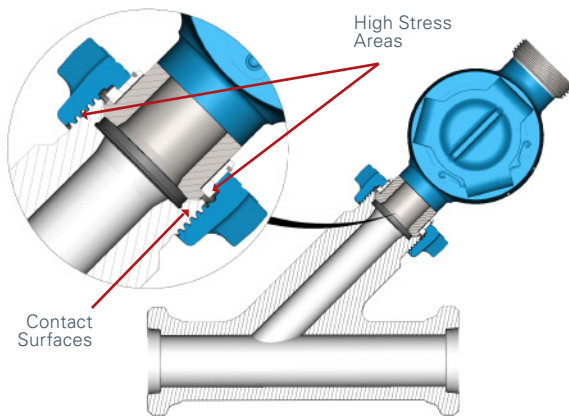

SPM® Safety Iron® Connection

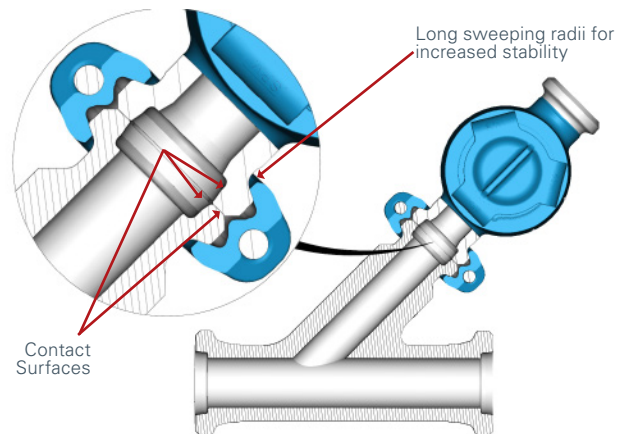

Hammer union connections feature only one contact seal surface, limiting the integrity of the connection. Hammer unions, with their thinner wall section at vital points and higher stress areas due to the jagged grooves of the threads, are more susceptible to damage as a result of vibration or side loading in harsh operating environments.

SPM® Safety Iron® connections have a greater surface contact area for a much more stable connection compared to hammer union seals. SPM® Safety Iron® flanges are also more robust with larger sweeping radii for reduced stress, additional strength and vibration resistance.

Trailer Flow Rate

The SPM® Safety Iron® true bore' design allows for larger diameters and provides greater flow rates than traditional hammer union connections.

SPM® Safety Iron® bpm Chart (4.00" ID)

Configuration	bpm	Main Lines	Stations	Per Station	Total bpm
10 Station	30	2	10	6	60
10 Station	30	3	10	9	90
12 Station	30	3	12	7.5	90
12 Station	30	4	12	10	120

Assembly Specifications

Trailer Frame

The SPM® Manifold Trailers with SPM® Safety Iron® connections utilize a dual-axle frame allowing users more freedom of additional spare irons, hoses, and tool boxes. Field experience has proven dual-axle frames are better suited to handle increased weight requirements, provide a more durable base with reduced frame deflection, and offer extended life in aggressive conditions. Some competitor's trailers feature a single axle and I-beam structural design that are more susceptible to the aggressive weight requirements resulting in more frequent repairs.

Flow Line Mounting

SPM® Safety Iron® Manifold Trailers feature flexible mounts, including coil spring (high pressure) and rubber anti-vibration supports (low pressure), greatly reducing the chance of fatigue cracks in integral components due to the vibration caused during transport and operation. SPM® Safety Iron® is mounted on wings designed to share weight distribution across adjacent stations with a robust and fatigue resistant design that is better suited for high vibration environments.

Trailer Suspension

SPM® Manifold Trailers with SPM® Safety Iron® connections are available with air-ride suspensions.

Landing Gear

SPM® Manifold Trailers with SPM® Safety Iron® connections come standard with a 5" landing gear system. Field experience has proven the 5" cylinders are better suited for increased loads seen in the field, allowing users full utilization of trailer frame capacity. A self-contained electric/hydraulic control unit operates off an electric DC motor powered by a 12-volt battery securely mounted on the trailer. Customers also have the option for a wet-kit system as well.

Configurations

SPM® Manifold Trailers with SPM® Safety Iron® connections are available in 8, 10, 12, and 16 station configurations for operating pressures up to 15,000 psi.

SPM® 8-Station Manifold Skid

The SPM® 8-Station Manifold Skid with SPM® Safety Iron® connections provides users with a manifold system utilizing many of the design features of SPM® Manifold Trailers in a more compact footprint for use in regions where transport of larger manifold trailers is challenging. The SPM® Manifold Skid can be transported and loaded/unloaded from a flatbed trailer utilizing a winch. The modular design of the skid, coupled with the high pressure iron mounted above the low pressure manifold greatly enhances the serviceability of the high pressure system during maintenance cycles. The lower profile of the high pressure iron also increases safety for the user as actuating the isolation valves can be achieved more efficiently.

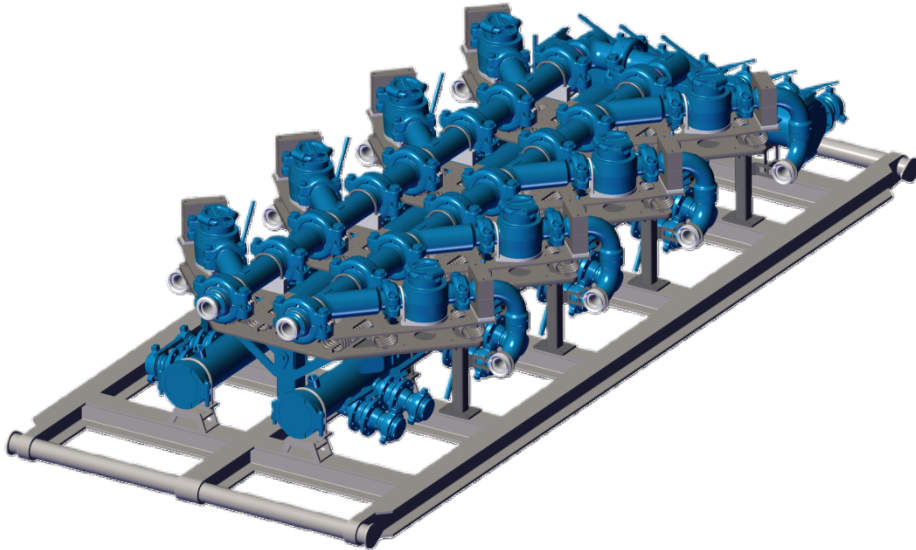

PATENT PENDING DESIGN

Features

- Skid engineered for improved carrying capacity, flexibility, and ease of transport
- Designed for domestic and international transportation requirements
- High pressure system utilizing coiled cable suspension provides vibration resistance to reduce risk of cracked integrals
- Modular high pressure system allowing easy removal and serviceability
- High pressure SPM® Safety Iron® Manifold rated for pressures up to 15,000 psi standard service and flow rating of 75 bpm

General Dimensions

- Overall width: Approx. 95.00"
- Overall length: Approx. 233.25"
- Weight: Approx. 17,500 lbs

SPM® Flow Line Safety Restraint (FSR) System

The destructive force of an unrestrained flow line rupture, regardless of the cause, can be devastating and catastrophic to both people and equipment. The SPM® Flow Line Safety Restraint (FSR) system is one of the industry's most utilized restraint systems designed to reduce the area of danger around high-pressure flow line disengagements. Operators and service companies have relied on the SPM® FSR system to enhance safety during pumping operations.

Product innovation, customer collaboration and a commitment to industry safety were the driving forces behind the development of this temporary flow line restraint product in 2000.

How the SPM® FSR System Works

The SPM® FSR system utilizes interlocking synthetic loops strung along the length of the flow line and attached to critical points of the flow line through smaller loops.

This assembly is then anchored to a suitable structural tie-down. Ribs and spines of the system transmit separation forces to the anchor point and restrict flow line movement and help dissipate energy.

Single Duty SPM® FSR System

The SPM® FSR system is available in a single duty rating, suitable for piping sizes up to 4" with a pressure rating of 15,000 psi and 3" with a pressure rating of 20,000 psi. The system is flexible enough for a variety of flow line configurations and can be easily transported. All models are suitable for energized fluid, CO₂ and nitrogen operations.

Demonstrated Performance

The SPM® FSR System has been used in both onshore and offshore applications around the world since 2000 to increase safety during pumping operations. It has been tested and honored by the industry for its innovation and performance.

- "Best Mechanical Engineering Innovation Award" from the American Society of Mechanical Engineers in 2002
- Accepted by WorkSafeBC (the Workers' Compensation Board of British Columbia) as in compliance with a government mandate that flow line piping systems be anchored and restrained during well testing or stimulation operations
- Mandated by several major E&P companies for use during pumping operations

Additionally, Weir recently reinvested almost \$500,000 into practical performance testing of this product line. In conjunction with an independent third party research institute, Weir has demonstrated this product's first in class technical design.

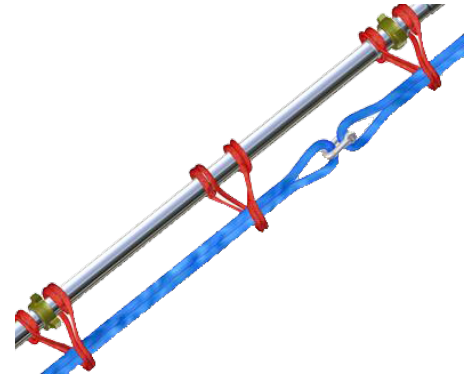

US PATENT 6,481,457

UK PATENT 2,370,869

Size and Pressure Rating

Nominal Iron Size	Pressure (psi)
2"	30,000 and below
3"	20,000 and below
4"	15,000 and below

NOTE: These load ratings are valid for gas and liquids in both energized and non-energized services.



Destructive testing conducted with a designed failure at 22,500 psi on up to 4" iron utilizing SPM® FSR



Testing validated SPM® FSR's ability to reduce the danger area around high pressure hydraulic fracturing operations.

FSR Rental Program

Weir maintains a fleet of rental SPM® FSR system units at its strategically located service centers around the globe for onsite delivery. The rental fleet undergoes rigorous inspection per Weir engineering specification. Each component features identification and inspection badges that indicate its compliance with regulations. Rental storage trailers are also available to store and organize the SPM® FSR system and make transport of component parts safe and convenient. Weir technicians will deliver the unit to a site as requested and provide onsite installation services.

The SPM® FSR system has performed successfully in flow line disengagements on many occasions. It has become a leading industry choice for temporary flow line restraints to enhance safety during pumping operations. Call Weir today for specific information about the SPM® Flow Line Safety Restraint (FSR) system.



Safety Hammer®

The SPM® Safety Hammer® union assembly device promotes a safer work environment by reducing the dangers associated with assembling hammer union connections using a sledgehammer. The SPM® Safety Hammer® device is composed of two main parts: a high strength alloy steel adaptor and pneumatic hammer. The steel adaptor can be changed out as needed to fit different union sizes. In order for the SPM® Safety Hammer® device to function as

intended, Weir recommends 29 SCFM per device, with an air pressure of 90 psi and 1/2" air supply hose size. The SPM® Safety Hammer® device will make up and break down the hammer union depending on its orientation.

To use the SPM® Safety Hammer® device, simply hand-tighten the hammer union connection until the wing nut ceases to rotate. Slide the SPM® Safety Hammer®

adapter over the wing nut so that it bears against one of the three lugs. Orient so that the impact tool striking the wing nut lug will tighten the connection. Apply a turning force to the gooseneck handle until the wing nut ceases to rotate. Squeeze the trigger and continue to apply a slight turning force to the gooseneck handle. The hammer union will be quickly tightened.

SPM® Safety Hammer® Assemblies and Spares

Type	Size	Cage Fig. Rating	Part Number	Weight (lbs / kg)
Complete Assembly	2"	1502	2A26689	31 / 14.1
Complete Assembly	3"	1502	2A26699	35 / 15.9
Complete Assembly	4"	200 & 206	2A26886	35 / 15.9
Complete Assembly	4"	602 & 1002	2A26709	35 / 15.9
Pneumatic Hammer			2A26730	18 / 8.2
Hammer Tool			2P27058	1 / .5
Cage	2"	1502	2P26690	7 / 3.2
Cage	3"	200 / 206	2P26887	8 / 3.6
Cage	3"	1502	2P26700	8 / 3.6
Cage	4"	1002	2P26710	8 / 3.6

NOTE: Other parts or configurations may be available. Contact Weir for specific details.

NOTE: Listed weights are approximate.



Inspection Services

Weir offers reliable flow control inspection and rebuild services through its extensive global network of service centers, mobile inspection units and customer embedded facilities. Qualified technicians perform inspections on both SPM® and competitor flow control product according to customer requirements. Rugged handheld computers guide technicians through all processes outlined by the customer, which are maintained in the SPM® Asset Management Program (A.M.P.) database, and record the results of the inspection.

Below lists the processes that are generally performed for each of the designated inspection levels. Weir is able to amend its offering to meet the needs of its customers as required.

Level 1 Inspection:

1. Iron is cleaned and visually inspected for signs of cracking or erosion.
2. An ultra-sonic wall thickness test is performed per customer or OEM specifications.

3. Male subs, wing nuts, female (threaded) union ends, and swivel ball races are cleaned and tested with appropriate gauge kits as necessary.
4. Union connections have their seal rings replaced and wing nuts are ground to remove any burrs.
5. Swivels and plug valves are greased.
6. Iron is pressure tested to 100% of rated working pressure per customer or OEM specifications.
7. Iron is banded and data is logged into SPM® Asset Management Program.

NOTES:

- All iron is inventoried and serial numbers are input into SPM® A.M.P. prior to work beginning.
- Results of each test throughout the entire inspection process are logged into SPM® A.M.P.
- Customer is provided with an inspection report that details the results of each process.

Level 2 Inspection:

In addition to the tasks performed in Level 1 inspections, Weir performs these steps:

1. Iron is fully disassembled and thoroughly cleaned. Grease is removed using solvent where needed.
2. Elastomer parts are replaced. Other internal components are inspected and replaced as necessary.

Level 3 Inspection:

In addition to the tasks performed in Level 2 inspections, a magnetic particle inspection is performed on the iron prior to a pressure test.

Other Options

Within the iron inspection process, Weir offers additional services that can be performed at customer request.

SPM® Asset Management Program (A.M.P.)

The SPM® Asset Management Program (A.M.P.) is the ultimate tool for users to manage their treating iron assets. With detailed inspection history, access to critical material information, and intelligent reporting to assist in planning and inventory control, SPM® A.M.P. provides users with a wealth of data to assist in managing their frac fleet.

Weir also utilizes SPM® A.M.P. to provide inspection services to satisfy customer requirements. Weir inspection processes integrate customer inspection specifications and permission based controls into rugged hand-held computers that direct technicians both in the shop and at remote locations.

Asset Management

- Real-time customer access to detailed asset information through a secure internet-based portal, including equipment status, inspection history and material certifications
- Permissions based structure allows customers to configure asset attributes along a wide array of categories

Reporting

- An intuitive reporting structure allows users to customize reports based on a wide variety of asset characteristics or by operating business unit.
- Permissions based structure allows customers to manage their own user profiles through designated administrators.

Inspection Management

- Customer inspection criteria can be loaded into the system, dictating how inspections are performed.
- Rugged hand-held computers utilized by technicians in Weir service centers manage data between inspection tools, such as UT meters, and SPM® A.M.P.



Weir Edge™ Service Advantage builds on our strength in services to extend equipment life and reduce total cost of ownership. Weir Edge™ provides a three-pronged offering includes:

- 1) Engineering Expertise – our experts come on site to analyze issues and train customers
- 2) Equipment repairs and aftermarket support – we find the root cause to minimize NPT and maximize life
- 3) Customer enablement technologies – our technologies allow you to streamline inventories and maintenance

All together, Weir Edge™ delivers a comprehensive, advanced level of aftermarket services globally.

We have the largest global footprint covering all major basins, including a US network that puts us no more than 3 hours from anywhere you're working. Our service centers are staffed with certified refurbishment experts and embedded repair teams to operate mobile repair units. With Weir Edge™, you can count on reliable repairs and support, digital empowerment tools, and unbeatable engineering expertise.

EDGE

THE SERVICE ADVANTAGE



Repairs & Support

We go beyond fixing. We solve root causes to optimize equipment life.

- Pressure pumping service centers in every major basin
- 452 certified refurbishment experts strategically placed to provide optimal support
- 13-pt standardized flow inspection process to minimize downtime and enhance performance
- Industry leading SPM® SafeEdge™ rental systems

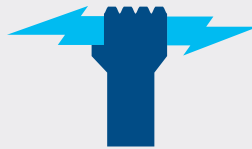

Empowerment Tools

Our technology helps you better manage inventories and streamline maintenance.

- RFID and A.M.P systems track assets and improve inventory efficiency by up to 97%
- Mobile application provide real-time site access to certifications
- Weir web portal platform stores product information and training



Engineering Expertise

Our experts can deploy to your site and solve issues across your operation.

- Engineering experts provide site evaluations and root cause analysis
- Includes training so customers can recognize and prevent impending failures
- 24/7 technical support availability

For additional Pressure Pumping support, please contact your Weir Edge™ Engineering Field Assist Team.

techservices@mail.weir

T +1 817 248 2703

www.edge.weir

Where You Need Us. When You Need Us.

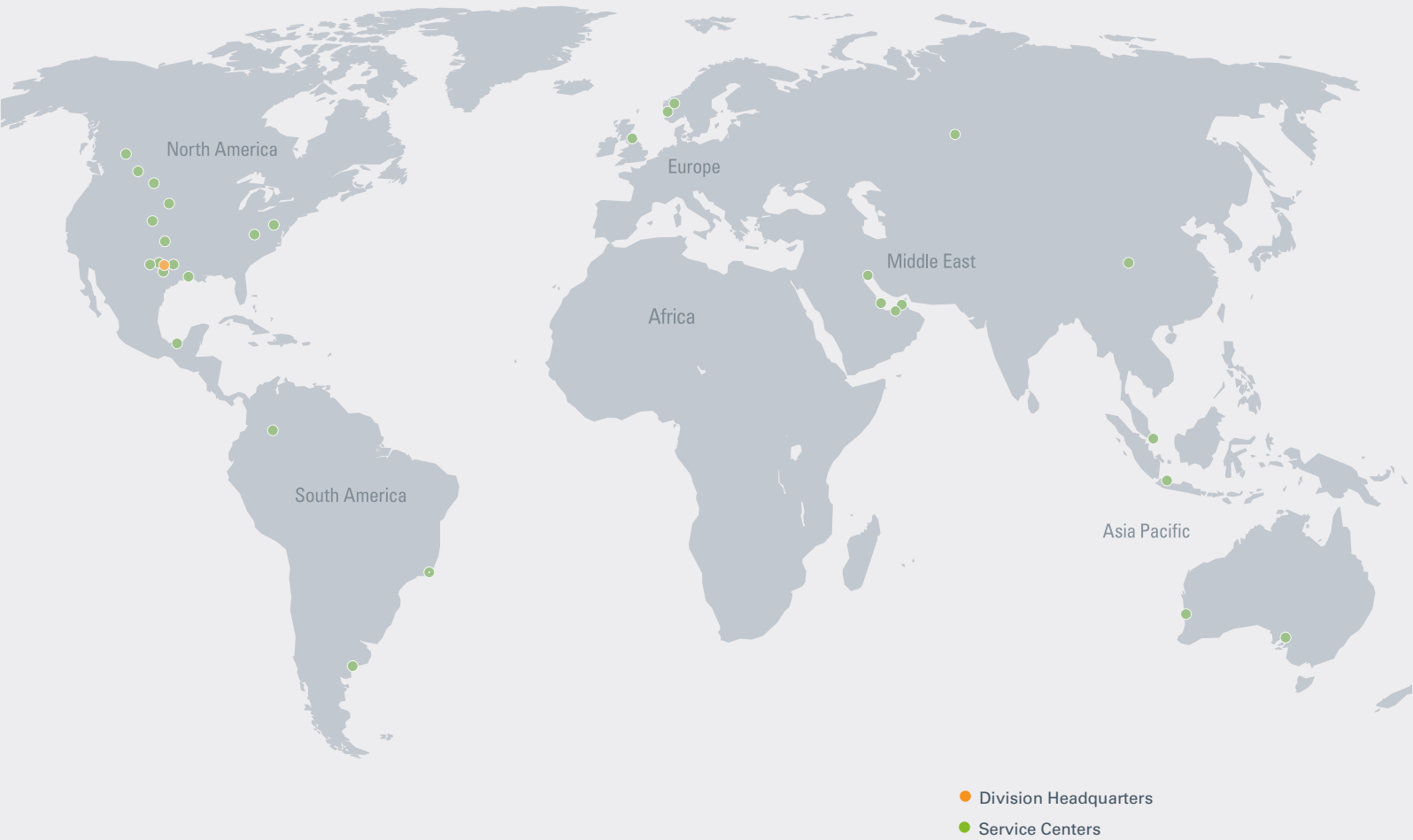

North America

Grand Prairie
Clairmont, Canada

Red Deer
Red Deer, Canada

Medicine Hat
Red Cliff, Canada

Williston
Williston, ND

Fort Lupton
Fort Lupton, CO

Midland
Midland, TX

Pleasanton
Pleasanton, TX

Fort Worth
Fort Worth, TX

Kilgore
Kilgore, TX

El Reno
El Reno, OK

Lafayette
Broussard, LA

Buckhannon
Buckhannon, WV

Williamsport
Muncy, PA

International

Villahermosa
Tabasco, Mexico

Colombia
Villavicencio, Meta, Colombia

Macaé
Macaé Brazil

Buenos Aires
Buenos Aires, Argentina

WESCO Abu Dhabi
Abu Dhabi, United Arab Emirates

Weir Services Dubai
Dubai, United Arab Emirates

Amco Weir – Saudi
Al Khobar,
Kingdom of Saudi Arabia

Aberdeen
Aberdeen, Scotland

Chengdu
Chengdu, China

Indonesia
Jakarta, Indonesia

Singapore

Russia
Tyumen, Russian Federation

Norway
Laksevåg, Norway

Norway
Ljosheimvegen 1, Norway

Adelaide
Adelaide, Australia

Perth
Perth, Australia

Sabail District
Baku, Azerbaijan



Oil & Gas

601 Weir Way
Fort Worth, TX 76108
USA

T +1 800 342 7458
F +1 817 977 2508

www.global.weir

Document PN: 2P41489

Release Date: 4-15-2020

Revision: J
